

Photosensitization by Reversible Electron Transfer: Theories, Experimental Evidence, and Examples

GEORGE J. KAVARNOS* and NICHOLAS J. TURRO*

Chemistry Department, Columbia University, New York, New York 10027

Received August 19, 1985 (Revised Manuscript Received December 26, 1985)

Contents

I. Introduction	401	2. Electronic Energy Levels	418
A. Background	402	3. Quenching Rate Constants vs. the Driving Force of Electron Transfer	419
B. Scope of the Review	403	B. Detection of Intermediates	419
II. Theoretical Concepts	404	1. Flash Photolysis Detection	419
A. An Overview of Quenching Pathways	404	2. ESR/Spin Traps	419
1. Quenching via Encounter Complexes	404	3. CIDNP	419
2. Quenching via Exciplexes	405	4. Luminescence	420
3. Quenching in Rigid Intramolecular Systems	406	5. Further Studies of Intermediates	420
4. Quenching by Hopping	406	C. Product Studies	420
B. Energetics	406	1. Scavengers of Intermediates	420
1. Free Energy Changes in Primary Electron Transfer	406	2. Structure of Products	420
2. Formation of Radical Ions in Solution	407	3. Generation of Intermediates	420
3. Stabilization of Exciplexes and Contact Ion Pairs	407	D. Kinetics	420
4. The Role of Energetics and Solvent Polarity in Energy Transfer	408	1. Quenching Studies	420
C. A Dynamic Model of Primary Electron Transfer Based upon the Franck-Condon Principle and the Classical Theory of Marcus	409	2. Magnetic Field Effects	420
1. Kinetic and Rate Expressions	409	E. The Effect of Solvent Polarity	420
2. Electronic and Nuclear Time Scales in Electron Transfer	410	IV. Examples of Electron-Transfer Photosensitization	421
3. Potential Energy Surfaces	410	A. Spectroscopic and Electrochemical Properties of the Sensitizer: Practical Considerations	421
4. The Electronic Interaction Energy: Adiabatic and Nonadiabatic Electron Transfer	410	B. Evidence that Primary Quenching Is via Electron Transfer	421
5. Electronic Barriers	411	1. Quenching of the Excited States of Metal Complexes	421
6. Nuclear Barriers	412	2. Quenching of the Excited States of Aromatic Hydrocarbons and Ketones by Amines	428
7. Useful Kinetic Relationships Derived from Self-Exchange Electron-Transfer Reactions	414	3. Intramolecular Quenching by Electron Transfer	431
8. Summary of Electronic and Nuclear Effects in Electron Transfer and Their Role in Energy Transfer	414	C. Reactions Photosensitized by Electron Transfer	437
9. The Relationship between Driving Force and Free Energy of Activation	415	1. Reactions of Alkenes	437
10. The Role of Entropy	417	2. Bond Cleavages, Ring Openings, Eliminations, and Isomerizations	439
11. Outer-Sphere and Inner-Sphere Electron Transfer	417	3. Valence Isomerizations	441
D. Pathways of Secondary Electron Transfer	417	4. Photooxygenations	443
III. Experimental Evidence for Electron Transfer	418	V. Prospects	445
A. Energetics	418	VI. Acknowledgments	446
1. Redox Potentials and the Weller Equation	418	VII. References	446
		I. Introduction	
		A. Background	
		Over the past three decades, the dynamic quenching of excited states has been an area of great interest to	

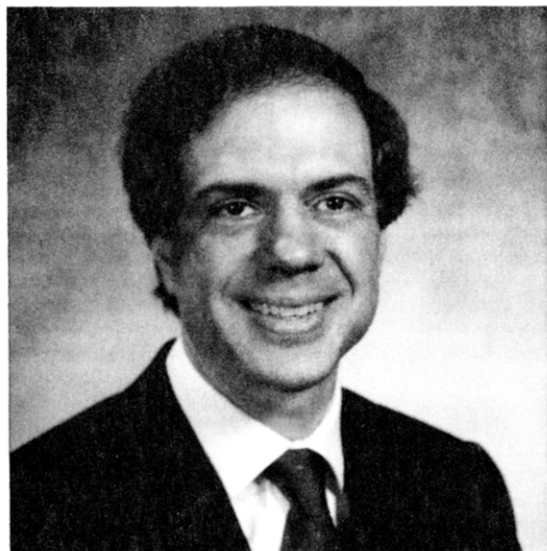

George J. Kavarnos performed experiments on the electron transfer chemistry of vanadium complexes as an undergraduate working under a National Science Foundation Research grant at Clark University in 1963–1964. After graduating from Clark with honors in chemistry, he went on to the University of Rhode Island to do his doctoral research. As a graduate student under Professor Paul Abell, he developed kinetic rate expressions for the photo-addition of hydrogen bromide to fluorinated ethylenes. He received his Ph.D. in physical organic chemistry in 1968, and went to work in the laboratory of Professor Nicholas Turro at Columbia University as a National Institutes of Health Fellow. At Columbia, Dr. Kavarnos pursued research in photochemistry with particular attention to spin-orbital coupling phenomena. He was a research fellow at the Albert Einstein College of Medicine, where he turned his attention to studying the allosteric properties of the hemoglobin molecule using time-resolved flash photolysis. Dr. Kavarnos is presently the director of BioAnalytical Laboratories (a division of CYTO Medical Laboratory, Inc.). His research interests include theoretical and applied aspects of photosensitization by electron transfer. He has published articles on photochemistry and clinical chemistry. He also holds a concurrent appointment as Adjunct Professor of Chemistry at the University of Rhode Island and has taught photochemistry at Saint Joseph College. Dr. Kavarnos is a Diplomate of the American Board of Clinical Chemistry.



Nicholas J. Turro was born on May 18, 1938 in Middletown, CT, and graduated from Wesleyan University in 1960 with a B.A. He studied under George S. Hammond at Caltech and received the Ph.D. in 1963. After a year's postdoctoral research at Harvard under the supervision of Paul D. Bartlett, he joined the faculty at Columbia University where he is currently the William P. Schweitzer Professor of Chemistry. He has received the Fresenius Award in Chemistry, the Pure Chemistry Award from the ACS, the Halpern Award in Photochemistry of the N.Y. Academy of Sciences, and the E. O. Lawrence Memorial Award of the U.S. Department of Energy. He is a member of the National Academy of Sciences and the American Academy of Arts & Sciences, and the author of *Modern Molecular Photochemistry*.

SCHEME I

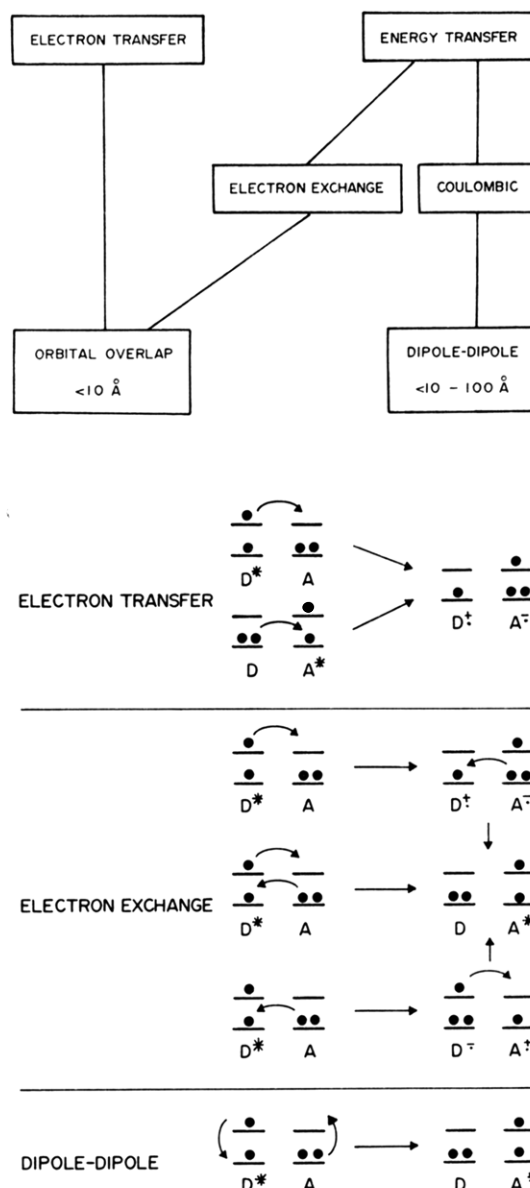

Figure 1. Schematic description of electron motion in electron- and energy-transfer quenching mechanisms (D = donor and A = acceptor). The solid circles (●) represent electrons. Electron transfer results in a radical ion pair. Energy transfer proceeds by an electron-exchange or dipole-dipole (Coulombic) mechanism.

photochemists. A classification of quenching processes into two general pathways—energy and electron transfer—has emerged and become well established (Scheme I). According to a simplified molecular orbital picture, energy and electron transfer can formally be described in terms of electronic motion between occupied and unoccupied orbitals of sensitizer and quencher (Figure 1). Quenching by electron transfer is a one-electron reaction in which an electron jumps from an occupied orbital of one reactant to an unoccupied orbital to the other. The sensitizer's excited state can be an electron donor or acceptor. In either case, quenching by electron transfer between uncharged species leads to a radical ion pair or a charge-transfer complex.

Quenching by energy transfer can take place by two fundamentally different mechanisms.¹⁻³ In the electron-exchange mechanism, two single independent

electron transfers—one in each direction—result in formation of the sensitizer's ground state and quencher's excited state. Energy transfer by the dipole-dipole mechanism operates by Coulombic resonance interactions (the "transmitter-antenna mechanism"), in which the oscillating electrons of an excited-state sensitizer are coupled with those of the quencher by an induced dipole interaction.

Electron transfer and energy transfer by electron exchange require a close approach for effective orbital overlap.¹ As a result, the "range of effectiveness" of these mechanisms is usually limited to distances of less than 10 Å. In contrast, Coulombic energy transfer does not involve orbital overlap and can be effective from collision distances of less than 10 Å and up to separation distances as large as 100 Å.³

Spin conservation is normally observed in both electron and energy transfer; i.e., the overall spin of the radical ion pair (electron transfer) or the spin of the acceptor's excited state (energy transfer) match the spin of the sensitizer's excited state. Triplet-triplet energy transfer is forbidden by the dipole-dipole mechanism and takes place by electron exchange.¹ This pathway can be used to generate reactive triplet states that normally cannot be formed by direct excitation.⁴ Singlet-singlet energy transfer, which proceeds by spin-allowed electron exchange and dipole-dipole interactions, has been used to probe the structure of biological macromolecules.⁵

For many years, photochemists restricted their investigations to energy transfer.^{1,6,7} In part, this was because of the relatively simple experimental designs required to observe and analyze the sensitized luminescence of an energy acceptor. Interest in electron transfer began in the early 1960s. For example, in 1963 Leonhardt and Weller reported the emission of complexes between perylene and dimethylaniline.⁸ These stoichiometric complexes were postulated as forming by electron transfer between the excited singlet state of perylene and the ground state of the amine. The term "exciplex" was eventually coined to describe these complexes.⁹ As used by photochemists today, an exciplex is defined as a two-component system in which charge and electronic excitation are shared by the components.⁹ Many quenching reactions which proceed by electron transfer involve exciplexes. This is particularly true of planar organic molecules. Exciplex formation involving these molecules correlates with their redox potentials, and dipole measurements confirm their charge-transfer nature.

During the 1970s photochemists were beginning to employ a new generation of laser flash spectroscopic, conductometric, and magnetic techniques to identify and study other types of intermediates which might play a role in electron transfer. The application of time-resolved laser flash spectroscopy permitted the direct observation of radical ion intermediates in reactions where theory predicted an electron-transfer pathway.¹⁰ Chemically induced dynamic nuclear polarization (CIDNP) was found to be invaluable in probing the kinetics of electron transfer.¹¹ Photosensitized reactions proceeding by electron transfer were also investigated and quickly found to have important synthetic applications. In particular, organic chemists discovered that photosensitized electron transfer could generate radical cations of electron-rich olefins and

SCHEME II

Primary Electron Transfer



Secondary Electron Transfer

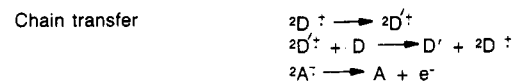
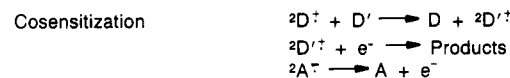
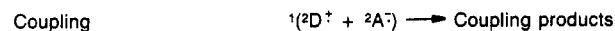
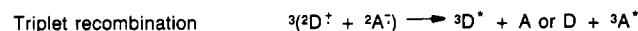
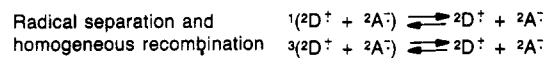
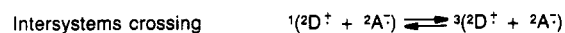

strained cyclic molecules, which could undergo a wide variety of interesting transformations.

Considerable progress was also made in the photochemistry of transition-metal complexes during the 1970s. Much of this effort was concerned with the bimolecular quenching of the excited states of transition-metal complexes by energy and electron transfer. These examples stimulated the development of theoretical descriptions of electron-transfer quenching which were rooted in the ideas of Taube,^{12,13} Libby,¹⁴ Marcus,¹⁵ and Hush.¹⁶ These concepts were extended to the electron transfer quenching of photoexcited metal complexes by Sutin¹⁷ and Balzani,¹⁸ who demonstrated the enormous scope and applicability of these reactions to solar energy conversion and the photoinduced decomposition of water.

More recently, research activity continues on wide variety of fronts, including the employment of new experimental schemes to test predictions of classical and nonclassical theories of electron transfer,¹⁷ the scope of photosensitized catalysis,¹⁹ the solution dynamics of exciplexes and radical ions,²⁰⁻²² photoinduced electron transfer in biological systems,²³ the search for novel reactions of organic molecules photosensitized by electron transfer,^{24,25} and the role of electron transfer in solar energy conversion.²⁶⁻³⁰ Photosensitized electron transfer remains a subject of intellectual challenge!

B. Scope of the Review

The subject of this review is electron transfer between excited-state and ground-state molecules. The discussion is limited to primary electron-transfer and secondary electron-transfer processes (Scheme II). By primary electron transfer, we mean the transfer of an electron between an excited-state and ground-state molecule to generate a charge-transfer species; secondary electron transfer refers to the electron-transfer pathways which following formation of the charge-

transfer complex. These may include reversible electron transfer to give the ground-state reactants, ionic dissociation into "free" ions, triplet recombination to generate an excited state of one of the reactants, or the formation of other charge-transfer intermediates and/or stable products:

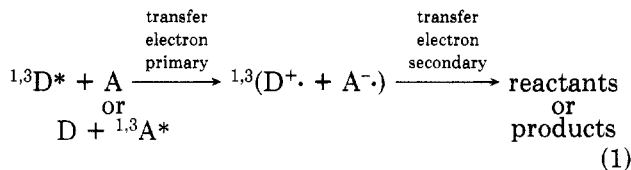

[In Section II, we shall sometimes adopt the practice of designating the excited state of the electron donor (D^*) as the sensitizer and the electron acceptor (A) as the quencher. This is arbitrary and done only for clarity.]

No attempt will be made to include systems in which ground-state interactions or complexation are prevalent. We will restrict the discussion to electron-transfer quenching processes in solution. Our objective will be to bring together the ideas developed by photochemists who have been involved in the study of photosensitized electron transfer over the last 15 years. We will attempt to formulate a unified and conceptual model of the energetic and structural factors that govern quenching by electron transfer. Another objective will be to present a "status report" on current experimental techniques and how these techniques can be effectively utilized to identify and study the electron-transfer mechanism. Finally, we will survey selected examples that serve as heuristic models of the principles presented in this review. Throughout this paper, an attempt is made to show how electron transfer differs from energy transfer by electron exchange in theory and practice and how these mechanisms can be distinguished experimentally.

II. Theoretical Concepts

A. An Overview of Quenching Pathways

An understanding of the dynamics of quenching by energy or electron transfer must take into account the positions and motions of the reactants in a given molecular environment. Since we are primarily concerned about processes in solution, we shall classify reaction pathways into those where (1) the reactants are mobile and free to approach to close distances within the lifetime of the excited partner and where (2) structural factors keep the reactants separated at a fixed distance during the lifetime of the excited partner. We shall describe encounter complexes, collision complexes, exciplexes, contact ion pairs, solvent-separated ion pairs, and free ions (Figure 2).

1. Quenching via Encounter Complexes

In a fluid medium, reactant molecules which are mobile and unrestrained by structure or environment may form an encounter complex prior to quenching (Figure 2). An encounter complex can be visualized as an intermolecular ensemble of an excited-state and ground-state molecule usually separated by a small distance ($\sim 7 \text{ \AA}$) and surrounded by several shells of

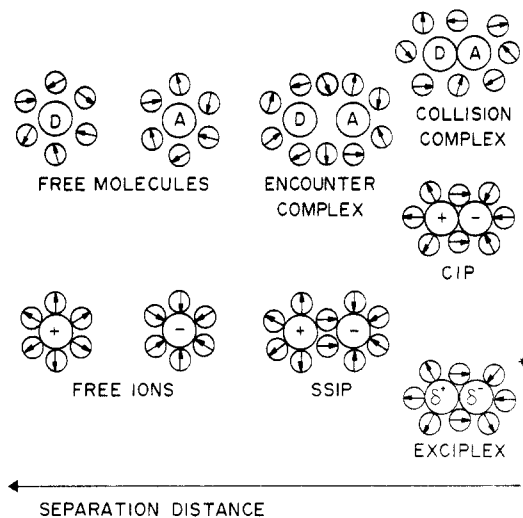
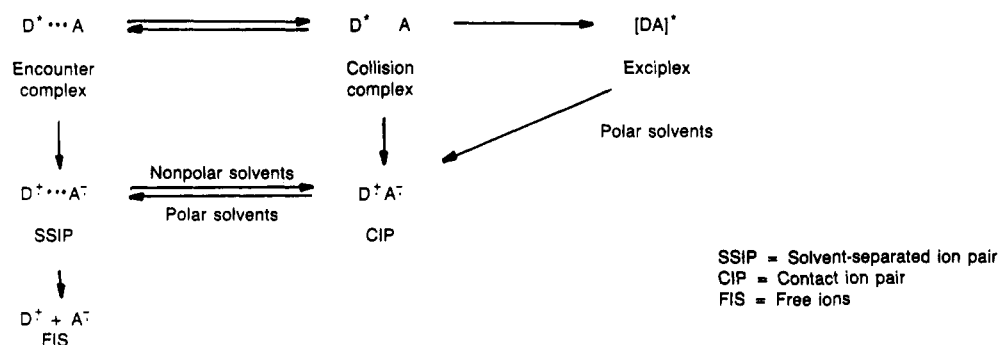

Figure 2. Schematic representation of donor and acceptor partners in solution at various separation distances preceding and following electron transfer. Surrounding solvent molecules (smaller circles) comprise the solvent cage. Both partners in the encounter complex shown in the figure are in the same cage. Collision within the cage results in a collision complex. The radical ion pairs (CIP = contact ion pair, SSI = solvent-separated ion pair, exciplex, and free ions) are stabilized by interaction with solvent dipoles. The charge-transfer intermediates may range from contact ("tightly held") ion pairs within the same solvent cage to free ions in separate, not adjacent, solvent cages.

solvent molecules; the innermost shell is the solvent cage.^{1,31-33} The structure of the encounter complex is affected by the size, shape, and charges of the reactants and by their interactions with the solvent cage. Excitation of the sensitizer usually takes place before formation of the encounter complex. The events preceding formation of the encounter complex can be described by the "random walk" hypothesis. According to this notion, molecules diffuse in solution by a series of one-dimensional random steps.¹ If we apply this concept to the formation of encounter complexes, we can envision reactant partners approaching one another in a series of randomized zig-zag steps.¹ Eventually, the molecules collide, separate, and undergo further collisions. A "typical" collision for an uncharged small organic molecule has a duration of about $\tau = 10^{-9}$ – 10^{-10} s. Quenching pathways may take place within the encounter complex, depending upon the driving force of these reactions. During the lifetime of an encounter complex, the reactants undergo structural (nuclear) and electronic (orbital) changes. The vibrational fluctuations, which determine the nuclear barrier of the pathway, have frequencies of $\sim 10^{12} \text{ s}^{-1}$. Thus, the lifetime of a typical encounter complex is usually of sufficient duration for rate-determining nuclear changes to take place. As shall be shown in sections II.B and II.C, nuclear reorganization is a critical aspect of electron transfer and must be considered when evaluating the rate-limiting barriers of this quenching pathway.

In quenching by electron transfer (Scheme III), if the transfer of an electron occurs during the lifetime of the "collision complex" (i.e., when the reactant partners are in contact), the charge-transfer species immediately formed is a "contact ion pair" (CIP, Figure 2). The collision complex can also separate slightly, undergo electron transfer, and generate a "solvent-separated" ion

SCHEME III



SCHEME IV

Electron transfer in systems linked by short chains

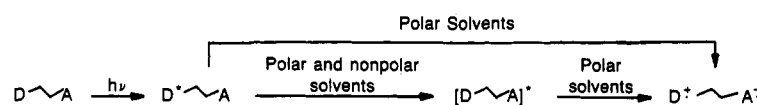

Electron transfer in systems linked by long chains

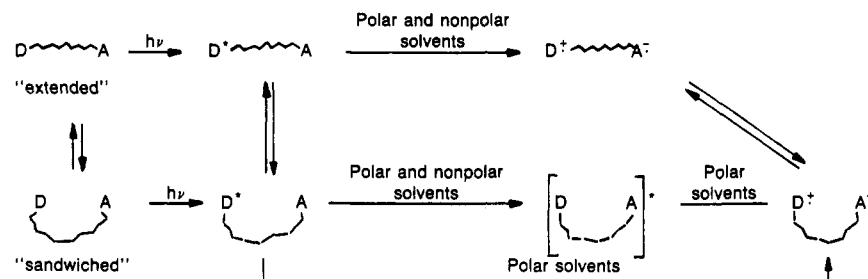

pair (SSIP, Figure 2). Following electron transfer, solvent molecules rapidly stabilize contact ion pairs and solvent-separated ion pairs. Thus, a contact ion pair may be "pried apart" by a solvent molecule and be converted into a solvent-separated ion pair or vice versa. Contact ion pairs and solvent-separated ion pairs are sometimes described as "geminate" ion pairs, provided that each ionic partner is a descendant of the same parental pair. If solvent-separated ions dissociate into the bulk of the fluid medium where they become separated by a large distance, they are classified as free and solvated ions. These ionic species are completely independent of one another, analogous to stable free radicals, and can exist as distinct, randomized, solvated, and long-lived species.

2. Quenching via Exciplexes

Quenching via exciplexes is a particularly important pathway when the reactants are planar organic molecules capable of forming "sandwiched" complexes. If the interaction between the reactants, one of which is electronically excited, is strong, an encounter complex can rapidly form an intermediate which may have a sufficiently long lifetime to undergo light emission (Scheme III). Such intermediates are termed exciplexes

and are characterized by strong binding energies (~ 5 – 20 kcal/mol), partial charge character on each reactant molecule, and large dipole moments, which reflect the degree of charge transfer.^{34,35} Typically, an exciplex is a long-lived, relatively stable, and structured electronically excited species. Experimental support for exciplexes is provided by the appearance of broad, structureless, and long-lived emission, although absorption and chemical reactions may also be used for characterization.

A molecular orbital wave function representation is used to express the electronic interaction in an exciplex as a summation of possible states (wave functions);³⁶

$$\Psi = c_1\psi(D^*A) + c_2\psi(DA^*) + c_3\psi(D^+ \cdots A^-) + c_4\psi(D^- \cdots A^+) + c_5\psi(DA) \quad (2)$$

where the coefficients pertain to the relative contribution of each state. If A is exclusively an electron acceptor and if ground-state interactions are neglected, eq 2 simplifies to

$$\Psi \approx c_1\psi(D^*A) + c_2\psi(DA^*) + c_3\psi(D^+ \cdots A^-) \quad (3)$$

If $c_3 \gg c_2$, the exciplex has pronounced charge-transfer character and will have a tendency to dissociate into radical ion pairs, especially in polar solvents. In the

SCHEME V

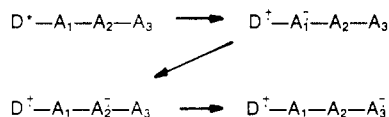
Electron hopping

extreme case, an exciplex is more accurately described as a contact ion pair. Emission from exciplexes proceeds by a vertical, Franck-Condon allowed transition from a minimum on an excited-state surface to a low-lying repulsive ground-state surface. If the transition to the low-lying ground-state surface involves a significant nuclear change, then emission may not be observed. Other decay processes, such as ionic dissociation into solvent-separated radical ions or chemical reactions may prevail. Such a nonemitting charge-transfer species is described as a "nonemitting" exciplex and has properties similar to those of a contact ion pair. For $c_3 \ll c_2$, exciplex formation leads to energy transfer. In such a case, exciplexes tend to emit light or undergo separation to form the excited state of the acceptor and ground state of the donor.

3. Quenching in Rigid Intramolecular Systems

Electron and energy transfer between reactants unable to form encounter complexes can still be important at distances even greater than those normally predicted by the "encounter-collision" concept (Scheme IV).^{1,10} This is especially true of rigid intramolecular systems in which a spacer molecule prevents the formation of an encounter complex. As shall be shown in section II.C, electron transfer is permitted in these systems because of favorable nuclear factors. With flexible spacer molecules as the connecting links, the situation is more complicated. Some flexible connecting links may in fact permit the formation of encounter complexes or exciplexes. Under these circumstances, the fate of charge-transfer intermediates formed by electron transfer reflects the structure and dynamic conformations of the molecular link. For example, reversible electron transfer to ground-state reactants or triplet recombination pathways may be much faster for two radical ions formed in close proximity than those generated at larger separation distances and unable to diffuse to encounter distances within their lifetime (section II.D).²⁶

4. Quenching by Hopping

Another quenching mechanism is energy and electron hopping.^{1,37-40} Electronic energy or an electron can hop or migrate from the donor to acceptor via a third molecule (Scheme V). The presence of the third species is required to serve as a relay which assists in propagating the excitation or electron. This mechanism has been proposed for intramolecular electron transfer in rigid molecules in which a third functional group, a "charge carrier", consecutively accepts and donates the electron.³⁹ Energy and electron hopping can also take place between intermolecular species with participation of solvent molecules.

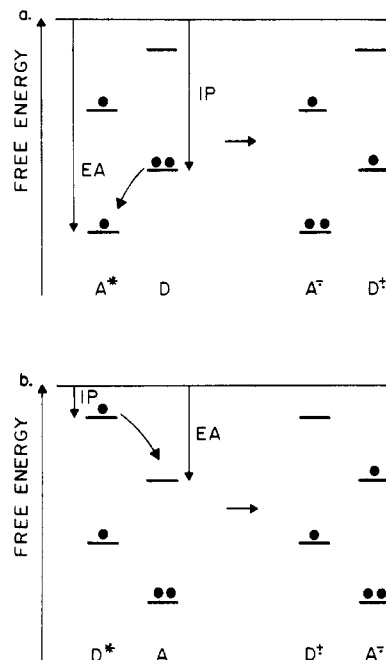

Figure 3. Energetics of electron transfer when (a) the sensitizer is the electron acceptor and (b) the sensitizer is the electron donor (IP = ionization potential of donor and EA = electron affinity of acceptor).

B. Energetics

1. Free Energy Changes in Primary Electron Transfer

The feasibility of electron transfer between an excited-state sensitizer and a quencher is dictated by the overall change in free energy, ΔG , which accompanies the reaction.^{41,42} The condition of exothermicity ($\Delta G < 0$) is a major requirement and becomes an efficient mechanism for the quenching of an excited state, capable of competing with other pathways, including energy transfer.

For a bimolecular electron transfer between two ground-state species, the standard free energy change in the gas phase is given by²⁰

$$\Delta G = IP_D - EA_A \quad (4)$$

where IP_D is the ionization potential of a donor and EA_A is the electron affinity of an acceptor. IP_D and EA_A are normally estimated from the energies of the highest occupied molecular orbital and lowest unoccupied molecular orbital of the donor and acceptor, respectively.

When one of the reactants is an excited-state molecule, the role of free energy in electron transfer can be examined in terms of the simplified molecular orbital diagrams in Figure 3. As shown in this figure, the unoccupied orbital of the acceptor receives an electron from an occupied orbital of the donor in an exothermic process. Thus, the absorption of light energy reduces the ionization potential and electron affinity of both donor and acceptor:

$$IP_D = IP_D - E_D^* \quad (5)$$

$$EA_A = EA_A + E_A^* \quad (6)$$

If the donor is electronically excited, eq 4 takes the form

$$\Delta G = IP_D - EA_A - E_D^* \quad (7)$$

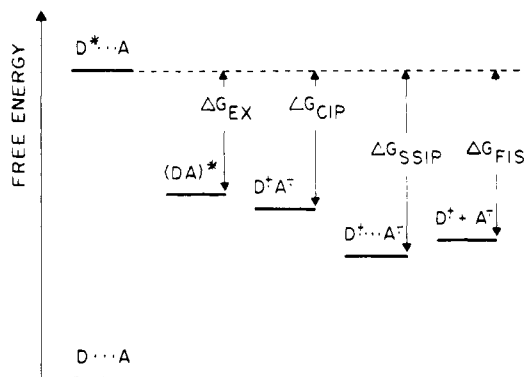
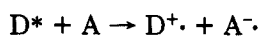

Figure 4. A comparison of free energy changes in electron transfer in polar solvents (EX = exciplex; CIP = contact ion pair; SSIP = solvent-separated ion pair; FIS = free ions).

In general, simple rules for determining the feasibility of electron transfer can be derived from eq 5 and 6:



$$IP_{D^*} - EA_A < 0: \text{ allowed} \quad (8)$$

$$IP_{D^*} - EA_A > 0: \text{ forbidden} \quad (9)$$

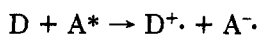

$$EA_{A^*} - IP_D < 0: \text{ allowed} \quad (10)$$

$$EA_{A^*} - IP_D > 0: \text{ forbidden} \quad (11)$$

2. Formation of Radical Ions in Solution

To give a more detailed picture of the overall free energy changes, we must account for Coulombic interactions and solvent stabilization effects of the charge-transfer intermediates formed in electron transfer.²⁰ Figure 4 shows some possible overall free energy changes in any of the charge-transfer intermediates shown in Figure 2.

We first consider a simple case where electron transfer results in formation of a solvent-separated radical ion pair. In solution, formation of an ion pair is accompanied by two stabilizing interactions: the formation of two charged species in close proximity which results in a Coulombic stabilization and the solvation of the ion pair. These stabilizing effects can be incorporated into eq 7 to obtain eq 12,

$$\Delta G_{\text{SSIP}} = IP_D - EA_A - E_{D^*} -$$

$$\frac{e^2}{2} \left(\frac{1}{r_D} + \frac{1}{r_A} \right) \left(1 - \frac{1}{\epsilon} \right) - \frac{e^2}{\epsilon d_{\text{SSIP}}} \quad (12)$$

solvation coulombic

where r_D and r_A are the radii of the donor and acceptor, ϵ is the solvent dielectric constant, and d_{SSIP} is the distance between the ions. The ionization potential and electron affinity in solution are related to the redox potentials of the donor and acceptor;

$$IP_D = E(D^{\cdot+}/D) - \Delta G(D^{\cdot+}) + \text{constant} \quad (13)$$

$$EA_A = E(A/A^{\cdot-}) + \Delta G(A^{\cdot-}) + \text{constant} \quad (14)$$

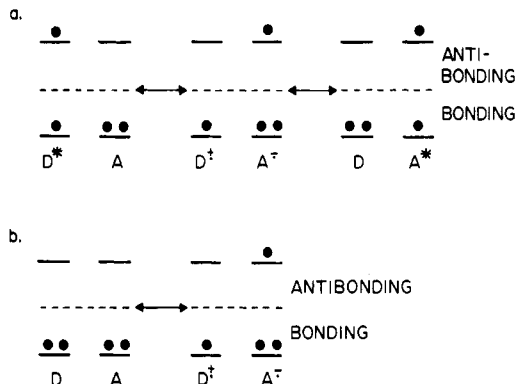

Figure 5. Molecular orbital descriptions of stabilization of (a) exciplexes and (b) ground-state complexes.

where $\Delta G(D^{\cdot+})$ and $\Delta G(A^{\cdot-})$ are the individual solvation energies:

$$\Delta G(D^{\cdot+}) + \Delta G(A^{\cdot-}) = -\frac{e^2}{2} \left(\frac{1}{r_D} + \frac{1}{r_A} \right) \left(1 - \frac{1}{\epsilon} \right) \quad (15)$$

Combining eq 12–15 gives the Weller equation (eq 16), which is used to calculate the free energy in quenching by electron transfer when the excited-state energy of the excited reactant and redox potentials of both reactants are known:⁴²

$$\Delta G_{\text{SSIP}} \text{ (kcal/mol)} = 23.06 \left[E(D^{\cdot+}/D) - E(A/A^{\cdot-}) - \frac{e^2}{\epsilon d_{\text{SSIP}}} \right] - E_{D^*} \quad (16)$$

Equation 16 contains the “basic ingredients” for determining whether electron transfer between an excited-state and ground-state molecule is spontaneous. In the derivation of eq 16, it was implicitly assumed that the geometry of the excited state does not differ from the ground state and that entropy changes accompanying the formation of the radical ion pair from the reactants are negligible. These assumptions may not be valid if there are significant structural changes accompanying electron transfer. In practice, however, entropic changes are neglected when calculating overall energy changes. The role of entropy in electron transfer quenching is treated in more detail in section II.C.10.

If the solvent-separated ion pair dissociates into free ions so that they are sufficiently separated beyond their respective Coulombic fields or if the solvent has a large dielectric constant, the Coulombic energy term can be neglected. In acetonitrile, the Coulombic energy is less than ~ 1.3 kcal/mol (0.06 eV) at separation distances exceeding ~ 7 Å. Equation 16 then simplifies to

$$\Delta G_{\text{FIS}} \text{ (kcal/mol)} = 23.06 [E(D^{\cdot+}/D) - E(A/A^{\cdot-})] - E_{D^*} \quad (17)$$

3. Stabilization of Exciplexes and Contact Ion Pairs

In exciplexes, the stabilizations resulting from overlap between the lowest antibonding orbitals or between the highest bonding orbitals is shown in Figure 5a.⁴³ The mixing between the antibonding or bonding orbitals of the locally excited state and the radical ions is stabilizing. On the other hand, the charge-transfer state formed from an excited singlet state sensitizer may have

some ground-state character mixed into its wave representation. (Spin selection rules forbid mixing between a ground-state singlet pair and a triplet radical pair.) This interaction involves the mixing of antibonding with bonding orbitals (Figure 5d) and results in a loss of energy which is proportional to the contribution of $DA \leftrightarrow D^+ \cdot A^-$. The net energy change is given by the difference in destabilization and stabilization energies, $\Delta E_{EX} = E_{stab} - E_{dest}$.

The derivation of free energy terms for exciplex pathways involves exciplex solvation, Coulombic attraction between reactants, and orbital stabilization terms (Figure 4), as given by eq 18

$$\Delta T_{EX} = IP_D - EA_A - E_{D^*} - \frac{\mu^2}{\rho^3} \left(\frac{\epsilon - 1}{2\epsilon + 1} \right) - \Delta E_{EX} - \frac{e^2}{d_{EX}} \quad (18)$$

where μ is the dipole moment of the exciplex, ρ is its radius, and d_{EX} is the distance between the two partners in the exciplex. The exciplex solvation term expresses the stabilization of the exciplex in a solvent of a specified dielectric constant.^{20,44}

In polar solvents, exciplexes can dissociate rapidly, since the resulting solvent-separated ions can be stabilized by interaction with solvent molecules.⁴⁵ In the formation of solvent-separated ions via the exciplex pathway, the free energy gained from solvation and Coulombic interactions of the solvent-separated ions must exceed the free energy required to dissociate the exciplex:

$$\frac{e^2}{2} \left(\frac{1}{r_D} + \frac{1}{r_A} \right) \left(1 - \frac{1}{\epsilon} \right) + \frac{e^2}{\epsilon d_{SSIP}} > \frac{\mu^2}{\rho^3} \left(\frac{\epsilon - 1}{2\epsilon + 1} \right) + \Delta E_{EX} + \frac{e^2}{d_{EX}} \quad (19)$$

In polar solvents with $\epsilon > 7$,²² exciplex dissociation into solvent-separated radical ions is favored for exciplexes where $\Delta E_{EX} = 0$. However, if the stabilization of the exciplex is sufficiently large ($\Delta E_{EX} > \sim 7$ kcal/mol), radical ion formation is less likely and exciplex emission can be observed.⁴⁴

We can apply a similar line of reasoning to the formation of solvent-separated ions via the intermediacy of a contact ion pair as a result of electron transfer between colliding spherical molecules (Scheme III), when orbital interactions are not so strong as to favor exciplex formation. Under these conditions, we can derive the free energy of formation of a contact ion pair;⁴⁴

$$\Delta G_{CIP} = IP_D - EA_A - E_{D^*} - \frac{\mu^2}{\rho^3} \left(\frac{\epsilon - 1}{2\epsilon + 1} \right) - \frac{e^2}{d_{CIP}} \quad (20)$$

where μ now refers to the dipole moment of the contact ion pair and $d_{CIP} = r_A + r_D$ and is the center-to-center separation distance between the ions.

Equations 18 and 20 can be used to derive eq 17, provided that free ions are the final result of pathways involving exciplexes or contact ion pairs. Equation 17 can therefore be used to calculate the net free energy change for formation of free ions regardless of the details of the intermediate pathways.

In order to give a more complete description of the effects of solvent polarity on electron transfer, however,

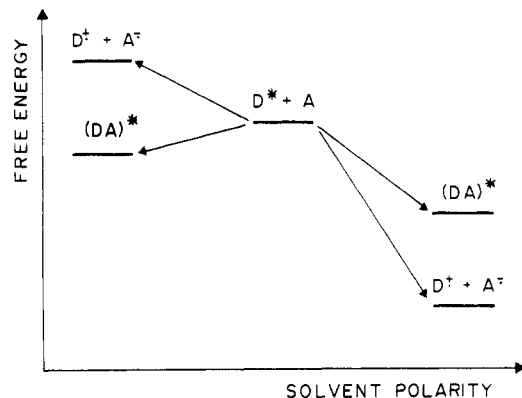

Figure 6. The effect of solvent polarity on the energetics of electron transfer.

we must account for the possibility of “unrelaxed” charge-transfer intermediates.⁴⁵ This topic is covered in detail in section II.C. At this point, we will simply state that following formation of charge-transfer intermediates, solvent molecules tend to reorient around the reactants in response to electronic changes. Polar solvent molecules are more effective because they can assist in the stabilization of the “new” charge of each reactant partner. As solvent molecules rearrange around an exciplex or contact ion pair during solvation, they may “pry apart” the “tightly held” ion pair. The result is a “loosely held” solvent-separated ion pair (Figure 2). In nonpolar solvents, solvent stabilization of ion pair states is weak, and the tendency is for the exciplex to remain “tightly held” in the absence of significant solvent stabilization.⁴⁶ Under these conditions, radiative and nonradiative pathways, which deactivate the exciplex compete effectively with ionic dissociation, and exciplex emission can be observed.^{21,47}

In summary, the overall thermodynamics of the quenching of excited states by electron transfer are highly sensitive to the dielectric constants and degree of polarity of solvents. Although solvent-separated radical ions (and subsequently, free radical ions) can be formed from encounter complexes, contact ions, and exciplexes, the dynamic interconversion of various charge-transfer states is largely influenced by interactions with the surrounding molecules. The effects of solvent polarity on the energetics of electron transfer are summarized in Figure 6.

4. The Role of Energetics and Solvent Polarity in Energy Transfer

Energy and electron transfer are thermodynamically controlled pathways. The likelihood of either mechanism being operative depends to a large extent on the overall free energy changes. Most sensitized reactions proceed exclusively by one or the other pathway, depending on the free energy changes. In some donor-acceptor systems, however, both mechanisms may be permitted by overall energetics. In such systems where competitive pathways take place, the relative feasibility of one pathway may also be determined by kinetic factors. We may predict that both pathways will proceed at faster rates at more exothermic free energies. However, at least in the case of electron transfer, the relationship between the overall free energy change and

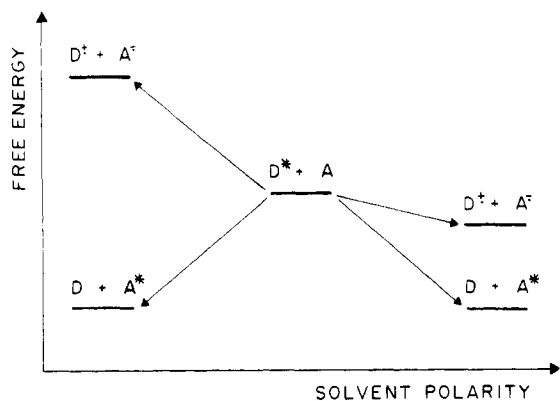

Figure 7. A comparison of the effect of solvent polarity on electron and energy transfer.

the kinetics is not obvious. This important question will be dealt with in section II.C.

Another important consideration is the effect of solvent. Solvent polarity affects energy and electron transfer in a significantly different manner. Quenching by energy transfer does not normally involve nor generate highly polar intermediates; therefore, solvent effects should be minor for this pathway. Figure 7 demonstrates the possible competition between energy and electron transfer as the solvent dielectric constant is changed.

C. A Dynamic Model of Primary Electron Transfer Based upon the Franck-Condon Principle and the Classical Theory of Marcus

Up to this point we have considered the thermodynamics of the primary electron transfer step. We now turn to the important question of reactivity and explore the effects of structure and environment on the rate of electron transfer.

The electronic and nuclear barriers to electron transfer are examined in this section. We draw upon a classical theory of electron transfer between ground-state reactants,^{15,16,48-54} which was modified for the quenching of excited states by electron transfer.^{17,18,26,29,32,42} Although the classical theory was originally formulated for weakly interacting ground-state molecules, it serves as a powerful tool for understanding the barriers in excited-state electron transfer.

1. Kinetic and Rate Expressions

Before we proceed to present a model which describes the effects of electronic and nuclear barriers, we must identify the rate constants which are used when discussing quenching by electron transfer. It is useful to start with familiar expressions that are often used to describe bimolecular quenching by energy transfer.^{29,55,56} An expression for the efficiency of electron transfer quenching can be derived along the same lines as has been done for energy transfer,¹

$$\Phi_{\text{et}} = \phi_{\text{es}} \frac{k_{\text{q}}[\text{A}]}{k_{\text{q}}[\text{A}] + k_{\text{d}} + k_{\text{q}}'[\text{A}]} \quad (21)$$

where ϕ_{es} is the efficiency of excited-state formation (by direct excitation or excitation followed by intersystems crossing), k_{q} is the overall bimolecular rate constant of

electron transfer, k_{q}' is the rate constant for bimolecular quenching reactions other than those described by k_{q} , and k_{d} is the rate constant for unimolecular decay of the excited state. According to eq 21, electron transfer is a major quenching pathway only to the extent that it is competitive with other pathways for deactivation of the excited state, which may include emission decay, radiationless transitions, energy transfer, chemical reaction, and so on. In solution, k_{q} is actually a composite of several rate constants:^{42,52}

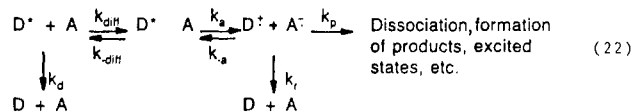

In eq 22, k_{diff} and $k_{-\text{diff}}$ are diffusion-controlled rate constants, k_{a} and $k_{-\text{a}}$ are bimolecular "activation energy controlled" rate constants of electron transfer, k_{r} is the rate constant for reversible electron transfer to ground-state reactants, and k_{p} is the rate constant for radical ion dissociation, formation of excited states, or trapping reactions in the presence of scavengers. Applying a steady-state treatment to the various intermediates in eq 22 leads to⁴²

$$k_{\text{q}} = \frac{k_{\text{diff}}}{1 + \frac{k_{-\text{diff}}}{k_{\text{a}}} + \frac{k_{-\text{diff}}k_{-\text{a}}}{(k_{\text{p}} + k_{\text{r}})k_{\text{a}}}} \quad (23)$$

Equation 23 can be simplified if it is assumed that electron transfer is exothermic. Given this assumption, $k_{-\text{a}} \ll k_{\text{a}}$, and eq 23 becomes

$$k_{\text{q}} = \frac{k_{\text{a}}k_{\text{diff}}}{k_{\text{a}} + k_{-\text{diff}}} \quad (24)$$

Introducing a further assumption that $k_{\text{diff}} = k_{-\text{diff}}$ leads to the following relationship:^{32,57}

$$\frac{1}{k_{\text{q}}} = \frac{1}{k_{\text{a}}} + \frac{1}{k_{\text{diff}}} \quad (25)$$

From eq 26, it can be deduced that under conditions of slow electron transfer, i.e., $k_{\text{a}} \ll k_{\text{diff}}$, the observed rate of quenching of an excited state is equal to the "activated" rate of electron transfer, i.e., $k_{\text{q}} \sim k_{\text{a}}$. Under conditions of rapid electron transfer, i.e., $k_{\text{a}} \gg k_{\text{diff}}$, the observed rate of quenching is simply given by the diffusion-controlled rate constant for the medium in which the reaction takes place, i.e., $k_{\text{q}} \sim k_{\text{diff}}$. A reaction system which can be chosen so that $k_{\text{a}} \sim k_{\text{q}}$ can be particularly instructive, since in this case the measured rate is related to the barrier for electron transfer.

We can therefore utilize the following relationships:

$$k_{\text{a}} = A k_{\text{et}} \quad (26)$$

where

$$k_{\text{et}} = \mathbf{k} \exp(-\Delta G^*/RT) \quad (27)$$

where A is the collision frequency at unit molar concentration of reactants within the encounter complex, \mathbf{k} is a constant which reflects the electronic barrier of the reaction, and ΔG^* is the free energy of activation representing contributions from nuclear barriers.

Electronic and nuclear barriers are rate determining in electron transfer and are included in eq 27. Either electronic barriers primarily influence the rate ($k \ll 1$ and $\Delta G^\ddagger = 0$, or nuclear barriers are rate determining ($k \sim 1$ and $\Delta G^\ddagger > 0$).

In highly viscous media, at low temperatures, or in rigid intramolecular systems, the rate of quenching, k_q , is given by k_a . Under these circumstances, electron transfer is permitted within the Perrin "quenching sphere", which defines the spatial dimensions where quenching is most probable.⁵⁸⁻⁶⁰ For these systems where diffusional motion is slow, k_{et} can be calculated from eq 26 and 27. The magnitude of k_{et} depends upon the freedom of an excited-state and ground-state molecule to explore a given set of electronic and nuclear configurations and ultimately find a suitable arrangement that permits electron transfer. If this "freedom" is restricted (as it may be in viscous solutions or at low temperatures), the most favorable electronic and nuclear configuration may be inaccessible, and electron transfer becomes severely retarded.

2. Electronic and Nuclear Time Scales in Electron Transfer

The Franck-Condon principle is the cornerstone of classical theories of electron transfer. As normally applied to spectroscopic transitions, the Franck-Condon principle states that the interatomic distances and nuclear momenta are identical in the initial and final states during the absorption or emission of light. Over 30 years ago, Libby applied the Franck-Condon principle to electron transfer in aqueous solutions.^{14,61,62} He noted that the transfer of an electron between two species is a relatively instantaneous event compared to the slower nuclear motions which must take place in order to accommodate the "new" electronic configuration in the surrounding inner coordination shells. For example, the exchange of an electron between $\text{Fe}(\text{H}_2\text{O})_6^{2+}$ and $\text{Fe}(\text{H}_2\text{O})_6^{3+}$ is slow because of the different metal-ligand bond lengths in these complexes. After a rapid self-exchange of an electron, the electronic configuration of each species does not "match" the original nuclear geometries. The final product state is obtained only after slow adjustments in bond lengths. Electron self-exchange between $\text{Fe}(\text{CN})_6^{3-}$ and $\text{Fe}(\text{CN})_6^{4-}$, however, is rapid because of the similar Fe-CN bond distances in both complexes.

In classical theories of electron transfer, the ideas of Libby are used in a somewhat modified form. Nuclear changes occur prior to electron transfer and are made possible because of collision between reactants and surrounding molecules. Before the transfer of an electron, the nuclear geometry of the reactants, including the surrounding solvent molecules, must be converted into a high energy, "nonequilibrium" or distorted configuration. The transition state consists of two high energy species which possess an equivalent nuclear but different electron configuration.

In the application of the Franck-Condon principle to the mechanisms of excited-state electron transfer, it is necessary to have a feeling for the large differences in time scales of electronic and nuclear processes (Table I). It is particularly important to observe that the frequency of electron motion, 10^{15} – 10^{16} s^{-1} , is faster than nuclear vibrational motion. The wide range of bimo-

TABLE I. Typical Frequencies and Rate Constants in Photosensitized Electron Transfer

electron motion (orbital jumps)	$\sim 10^{15}$ s^{-1}
nuclear motion (vibrational)	$\sim 10^{12}$ – 10^{14} s^{-1}
orientation of solvent dipoles	$\sim 10^{11}$ – 10^{12} s^{-1}
rate of resonant charge transfer	$\sim 10^{15}$ s^{-1}
diffusional rate constants	$\sim 10^9$ – 10^{11} M^{-1} s^{-1}
bimolecular rate constants of quenching by electron transfer	$\sim 10^5$ – 10^{12} M^{-1} s^{-1}
bimolecular rate constants of quenching by energy transfer	~ 1 – 10^{12} M^{-1} s^{-1}
bimolecular rate constants of electron exchange between ground-state molecules	$\sim 10^{-10}$ – 10^{10} M^{-1} s^{-1}

lecular rate constants of the quenching by electron transfer in solution (10^5 – 10^{12} M^{-1} s^{-1}) is dictated by electronic, nuclear, and diffusional changes which must occur during the lifetime of the excited photosensitizer. For comparison, it is interesting to note that rate constants of electron transfer between ground-state molecules span a much wider range.

3. Potential Energy Surfaces

In the literature on electron transfer, energy surface profiles conveniently express the changes in the potential energies of the reactant and solvent molecules at various stages of the reaction.^{15,42,63} These surface profiles display the potential energy of the reaction vs. the nuclear geometry which may consist of bond length, bond angle, molecular orientation, and positional changes.

In bimolecular quenching by electron transfer, two energy surfaces are of particular importance: (1) the reactant surface or initial state consisting of an excited molecule and ground-state molecule and (2) the product surface or final state consisting of the radical ion pair (Figure 8). Initially, excitation of the sensitizer brings the reacting system to an excited-state energy surface where thermal equilibration into a low energy vibrational state is rapidly established. The energy at the intersection of the excited-state surface and the product surface is the "nonequilibrium" or distorted nuclear arrangement which precedes electron transfer. Following electron transfer, nuclear relaxation rapidly establishes the thermally equilibrated radical ion pair. The arrangement of reactants prior to electron transfer is sometimes described as a "precursor complex". The complex formed following electron transfer is the "successor complex".³²

4. The Electronic Interaction Energy: Adiabatic and Nonadiabatic Electron Transfer

As an electron jumps from one reactant to the other, the reaction "switches" from the reactant to product surface at the intersection point, which consists of two isoenergetic electronic configurations with one distorted nuclear geometry. The probability of electron transfer at the intersection point is controlled by the electron interaction between reactant and product states.¹⁵ The magnitude of this interaction or "mixing" is given by the electronic coupling matrix, H_{if} , and results in a splitting of the energy surfaces.^{15,17} At one extreme, if a large electronic energy barrier separates the passage of the electron between the donor and acceptor orbitals, electronic interaction is vanishingly small, i.e., $H_{if} = 0$: the probability of electron transfer is small. k in eq 27

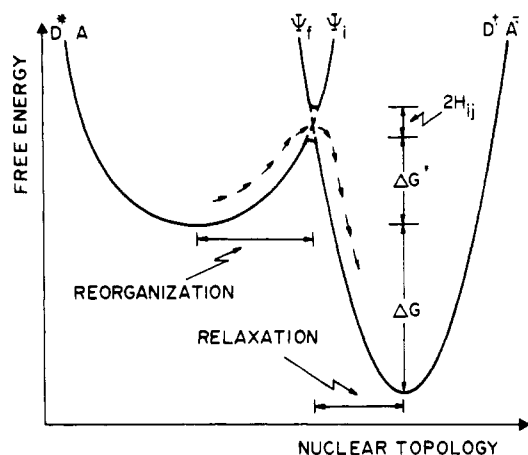

Figure 8. A potential energy surface description of photosensitized electron transfer. ΔG^* is the activation barrier for electron transfer. H_{if} is the electronic coupling matrix between initial and final energy surfaces. Classical theories of electron transfer apply to situations where $\Delta G^* \gg H_{if}$. ΔG is the overall free energy difference between reactant and product states.

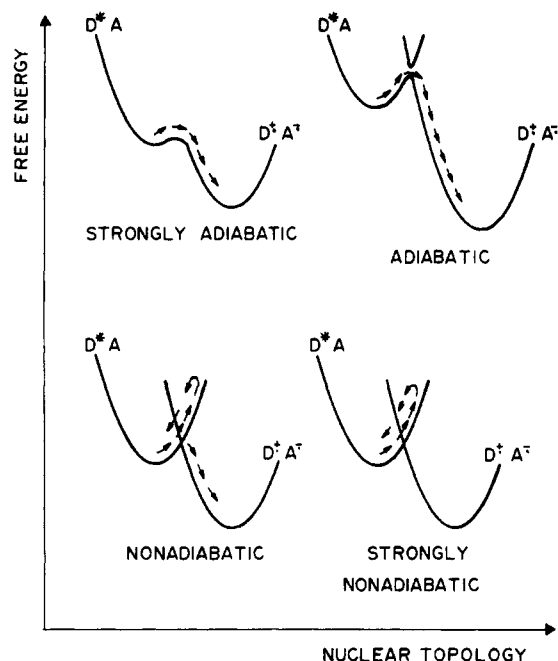

Figure 9. Potential energy surface descriptions for adiabatic and nonadiabatic electron transfer. Classical theories of electron transfer are applicable to systems which fall somewhere between adiabatic and nonadiabatic, i.e., $\Delta G^* \gg H_{ij}$.

approaches zero, since the reaction surfaces do not cross. If and when electron transfer occurs, it is defined as nonadiabatic, and the reaction coordinate proceeds abruptly from one surface to the other (Figure 9).

At large electron interaction energies, the reaction passes smoothly from the reactant to the product surface (Figure 9). The rate approaches a value of $\sim 10^{13}$ s^{-1} , which is the unimolecular rate of electron transfer within a transition state. In the strong interaction limit, k is approximately unity, and the reaction is defined as adiabatic. The electronic interaction can become so large in some cases that the two electronic intermediates in the transition state merge into one short-lived resonance stabilized state with a lifetime of $\sim 10^{-15}$ s. In this strongly adiabatic limit, the rate of charge transfer

TABLE II. Values of β for Several Electron-Transfer Quenching Reactions^a

reaction	β , \AA^{-1}
¹ tetramethyl- <i>p</i> -phenylenediamine* + phthalic anhydride	1.0
Ru[(CH ₃) ₄ phen] ₃ ²⁺ * + methylviologen (in glycerol)	1.5
¹ biphenyl*-steroid-acceptor	0.9
^{1,3} Zinc porphyrin*-quinone	1.1

^a Data from ref 68 and references therein.

approaches a maximum (10^{15} – 10^{16} s^{-1}). Under these circumstances, classical theories of electron transfer break down, since they do not apply to systems where the interaction energy is so large that the transition state is a resonance stabilized complex. Classical theories place special emphasis on nuclear changes and are applicable to weakly adiabatic electron transfer.

5. Electronic Barriers

Electron transfer consists of electron movement between orbitals. An electron may flow from a singly or doubly occupied molecular orbital of the donor to a fully vacant or half-vacant orbital of the acceptor. It follows that orbital overlap between the occupied and unoccupied orbitals must play an important role in electron transfer.^{64,65} In the very early stages of electron transfer, a nuclear perturbation, which may involve vibrational motion in the reactant or solvent molecules, starts the reaction on an energy surface. The reactant molecules begin to explore mutual configurations before "locking in" to a spatial orientation which is favorable for electron transfer. Because the orbitals act like "conductors" of the electron, structural and environmental factors which influence their mutual separation, orientation, and symmetry, or restrict their freedom of movement to find the most favorable spatial orientation, can profoundly influence the rate of electron transfer.

The electron interaction energy between two overlapping orbitals is inversely proportional to the separation distance and decreases exponentially from its maximum value when the donor and acceptor are in contact:^{2,66–68}

$$H_{if} = H_{if}^0 \exp[-\beta(d - d_0)/2] \quad (28)$$

In eq 28, d_0 is the electronic contact distance, and $d - d_0$ is the electronic edge-to-edge distance and is inversely proportional to the magnitude of the orbital overlap.⁶⁸ Equation 28 can be rewritten as

$$K = k^0 \exp[-\beta(d - d_0)] \quad (29)$$

where k^0 is the maximum probability of passage of an electron at the intersection point. According to eq 29, the rate of electron transfer decreases with separation distance. This rate constant can be calculated from values of β , which usually range from 0.9–2.0 \AA^{-1} (Table II). It is important to note that as an orbital parameter, β does not necessarily reflect the relative orientation of the donor and acceptor or the nature of the medium through which the electron travels.⁶⁸

Equation 29 can be used to estimate the time and distance scales of electron transfer during the lifetime of the excited partner. Typical values derived for several edge-to-edge distances are listed in Table III. It is evident that for a typical singlet lifetime of ~ 10 ns,

TABLE III. Rate and Distance Relationship in Photosensitized Electron Transfer

k_{et} , s ⁻¹	β , Å ⁻¹	$d-d_0$, Å
$\sim 10^3$	2.0	5
$\sim 10^5$	1.2	15
$\sim 10^8$	1.2	10
$\sim 10^9$	1.2	5
$\sim 10^9$	0.9	10

electron transfer can be observed only at close proximities or between molecules in which the donor-acceptor orbitals extend over large distances. The observation of electron transfer at large separation distances may sometimes be explained because of small overlap at these distances. Evidence of long-range photosensitized electron transfer is presented in section IV.B.3.

In addition to the separation distance, the spatial orientations and symmetries of the donor and acceptor orbitals must be considered.^{69,70} Both orientation and symmetry are important for effective orbital interaction. The symmetry of the orbitals is important in this description because mobile reactants tend to "seek" an orientation which gives maximum orbital overlap. If a symmetry element can be defined for the reaction coordinate and if an appropriate symmetry element can be assigned to donor and acceptor orbitals, then it is possible that state symmetries for the excited reactant and quencher as well as the radical ion pair can be derived and correlated.⁷¹⁻⁷³ Crossing between states of the same symmetry results in adiabatic electron transfer, whereas crossing between states of different symmetry gives rise to a nonadiabatic reaction. These notions of symmetry have been applied to electron transfer between excited-state molecules and amines (section IV.B.2).

A procedure for studying the effects of mutual orientation of donor and acceptor in nonadiabatic electron transfer has recently been published.⁷³ Calculations were performed on oblate nonspherical aromatic molecules, and the orientation dependence of H_{if} was analyzed by consideration of the shape and nodal character of the applicable wave functions (Figure 10). For a constant edge-to-edge separation distance, H_{if} is larger for reactants in a face-to-face orientation than when they are arranged end-to-end. If the center-to-center distance is kept constant, the electronic interaction is larger for the end-to-end orientation.

Thus, electron transfer is slow when orbital-electronic barriers—as dictated by separation distance, orientation, and symmetry—are significant. The net effect of electronic barriers is to inhibit electron motion between donor and acceptor orbitals. Photosensitized electron transfer in dilute and highly viscous media, where the reactants stay well separated, is therefore improbable, unless diffusion into the quenching sphere can take place during the lifetime of the excited state. The same notion applies if any unusual steric or structural effect prevent a close approach for effective electronic interaction.

Electron transfer via an exciplex pathway is very rapid because of the maximum positive orbital overlap achieved during exciplex formation. These reactions are usually strongly adiabatic because of strong resonance interactions and are characteristic of planar, aromatic organic molecules where symmetry⁷⁴ and steric factors⁷⁵ allow for effective electronic interaction.

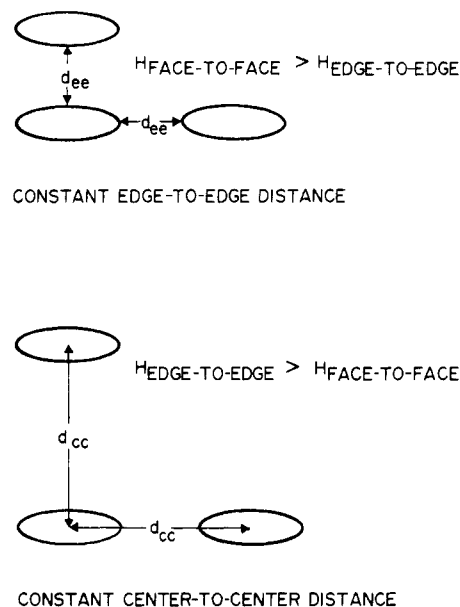

Figure 10. The effect of separation distance and orientation on the electronic coupling matrix in electron transfer. The figure shows donor and acceptor sites as oblate spheres. This type of model may be applicable to electron transfer involving large aromatic systems or porphyrins.

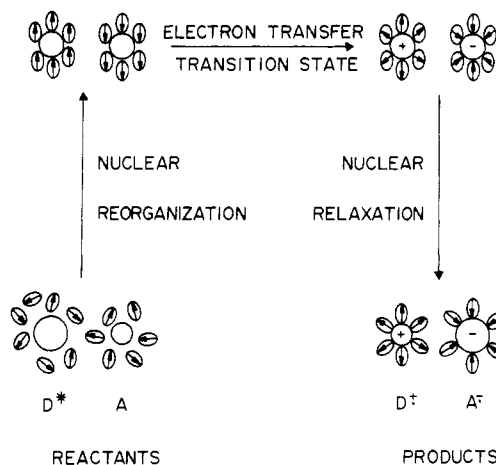

Figure 11. Nuclear changes preceding and following electron transfer. Nuclear reorganization and relaxation consist of changes in equilibrium bond lengths (shown by the size of the reactant molecules) and changes in the atomic and orientation polarization of the solvent molecules (shown by their elliptical shapes). The nuclear changes in the solvent molecules are slow compared to the rapid changes in the electronic polarization (shown by the arrows) which always remain in equilibrium with the charges on the reactants.

6. Nuclear Barriers

When the reactant orbitals interact so that $k = 1$ in eq 27, but not so strongly that resonance interactions dominate, the usual electronic barriers can in general be ignored; rather, the rate-determining factors are nuclear reorganization. Classical^{15,48-54} and semiclassical⁷⁶⁻⁷⁸ theories provide quantitative models for investigating these effects.

The nuclear changes involve structural adjustments in the reactants and surrounding solvent molecules in the stages preceding electron transfer (Figure 11). The nuclear perturbations bring the thermally equi-

brated complex of reactants and surrounding solvent molecules into the high energy, distorted, and nonequilibrium geometry of the transition state. The free energy of the transition state (ΔG^\ddagger) is a composite of the free energy changes brought on by the nuclear motions within the reactants (the inner coordination sphere) and the free energy change induced by nuclear motions within the solvent molecules (the outer coordination sphere).

A general expression has been derived which correlates the free energy of activation with the driving force of the reaction,^{15,50}

$$\Delta G^\ddagger = \Delta G_e^\ddagger + \frac{\lambda}{4} \left(1 + \frac{\Delta G'}{\lambda} \right)^2 \quad (30)$$

$$\lambda = \lambda_i + \lambda_0 \quad (31)$$

where ΔG_e^\ddagger is an electrostatic term, $\Delta G' = \Delta G + w_P - w_R$ (where w_P and w_R are work terms for the reaction), and λ_i and λ_0 are the intrinsic barriers corresponding to the bond length changes and solvent reorganization. Equation 30 permits a calculation of the free energy of activation of electron transfer.

The electrostatic term can be calculated from an expression that describes the Coulombic interaction between two charged and spherical reactants within a transition state,

$$\Delta G_e^\ddagger = \frac{Z_1 Z_2 e^2}{\epsilon_s d_{ts}} \exp \left[-d_{ts} \left(\frac{8\pi e^2 N_0 \mu_{is}}{1000 \epsilon_s K T} \right)^{1/2} \right] \quad (32)$$

where Z_1 and Z_2 are the charges on the molecules, d_{ts} is the distance between the two species in the transition state, N_0 is Avogadro's number, ϵ is the dielectric constant of the solvent, μ_{is} is the ionic strength of the medium, and K is the Boltzmann constant. Equation 32 is germane, of course, only to reactant partners which have net ionic charges. If the reactants are uncharged (for example, neutral organic molecules), electrostatic free energies and work terms can be neglected, and eq 30 can be rewritten as

$$\Delta G^\ddagger = \frac{\lambda}{4} \left(1 + \frac{\Delta G'}{\lambda} \right)^2 \quad (33)$$

a. Bond Length Changes. In addition to the electrostatic barriers described above, the barriers due to bond-order changes must also be taken into consideration. λ_i is the free energy change associated with the nuclear bond length changes within the reactant molecules. A classical expression, derived from a harmonic oscillator model, relates nuclear changes over all intramolecular vibrations with the free energy barrier,¹⁵

$$\lambda_i = \sum \left(\frac{f_i^{D,A} f_i^{D^+,A^-}}{f_i^{D,A} + f_i^{D^+,A^-}} \right) \Delta q_i^2 \quad (34)$$

where Δq_i is the change of interatomic distance and f_i is the force constant of this vibration. λ_i is equivalent to the Franck-Condon factor which results from the overlap of appropriate intramolecular vibrational frequencies in bimolecular reactions.

Bond length changes can sometimes occur in small ring compounds, amines, and some aromatic molecules.⁷⁹ In transition-metal complexes, changes in bond

TABLE IV. Differences in Metal-Ligand Bond Lengths in Oxidized and Reduced Forms of Metal Complexes

metal complex	Δl , Å
Fe(aq) ^{2+/3+}	0.14 ^a
Ru(bpy) ₃ ^{2+/3+}	0 ^a
V(aq) ^{2+/3+}	0.15 ^b
Co(aq) ^{2+/3+}	0.20 ^c
Co(NH ₃) ₆ ^{3+/2+}	0.17 ^c

^a From ref 77 and references therein. ^b From ref 79 and references therein. ^c Endicott, G. F.; Durham, B.; Kumar, K. *Inorg. Chem.* 1982, 21, 2437 and references therein.

lengths can be important when electron transfer involves metal-centered bonding and antibonding orbitals.³² Several examples are shown in Table IV. Since the Fe-H₂O bond lengths in Fe(H₂O)₆³⁺ and Fe(H₂O)₆²⁺ differ, an inner sphere nuclear barrier is predicted to play an important role in the oxidation and reduction of these aqueous iron complexes. However, bond length changes in the oxidation or reduction of Ru(bpy)₃²⁺ are negligible because electron transfer involves largely the π -orbitals of the bipyridyl ligands not the ruthenium-centered orbitals (section IV.B.1).

b. Solvent Reorganization. The reorganizational parameter which reflects changes in the polarization of solvent molecules during electron transfer is given by λ_0 .^{15,48,49} The polarization of the solvent molecules can be divided into two components: (1) the motion of the electrons in the solvent molecules, which always maintains equilibrium with the electronic charge which develops on the reactants (this electronic component responds rapidly and in phase with the rapid electronic fluctuations during the course of electron transfer) and (2) a nonequilibrium charge associated with the nuclear polarization of the solvent molecules (Figure 11). The latter corresponds to the slow, rate-determining changes involving the dipole moments of the solvent molecules which reorient themselves around the reactant molecules prior to electron transfer. The "new" geometry is the "nonequilibrium polarization" of solvent molecules in the transition state and is one out of many arrangements of solvent molecules. The arrangement which is most effective in stabilizing the transition state results in the lowest free energy of activation for electron transfer. This free energy barrier is given by

$$\lambda_0 = e^2 \left(\frac{1}{2r_D} + \frac{1}{2r_A} - \frac{1}{r_{AD}} \right) \left(\frac{1}{\epsilon_{op}} - \frac{1}{\epsilon_s} \right) \quad (35)$$

where r_D and r_A are ionic radii of the reactants ($r_{AD} = r_A + r_D$), ϵ_{op} is the dielectric constant of the medium which responds to the electronic polarization (ϵ_{op} is the square of the refractive index), and ϵ_s is the static dielectric constant or relative permittivity corresponding to the solvent dipole.

The role of solvent is underscored by the presence of ϵ_{op} and ϵ_s in eq 35. Solvent polarity is thus predicted to be important in determining the barrier to electron transfer. Since the transition state has charge-like character, the ability of the solvent to stabilize the transition state is a key factor in the solvent to stabilize the transition state is a key factor in the quenching of excited states by electron transfer. In Table V are listed a few values calculated for λ_0 , based upon the assumptions of spherical reactant shells and van der

TABLE V. The Effects of Solvent Dielectric and Refractive Index on λ_0^a

radii, Å			water	glycerol	acetonitrile	ethanol	benzene
donor	acceptor	ϵ_s	80.20	42.5	37.5	24.45	2.275
		n	1.3325	1.4746	1.34411	1.3614	1.50112
5	5		18.2	14.4	17.4	16.5	0.02
5	2		38.3	30.4	36.7	34.7	0.04
2	2		45.6	36.1	43.6	41.3	0.05

^aIn kcal/mol. Based on data in ref 79.

Waals contact. Although the calculated values do not always match experimentally obtained values,⁷⁹ they do give an intuitive idea of the changes in the free energy of activation according to changes in the solvent polarity and size of the reacting molecules: in general, solvents of high polarity or large donor-acceptor contact radii favor electron transfer.

Thus, the rate of electron transfer may be "controlled" by the dielectric constant of the solvent.⁸⁰⁻⁸² Electrostatic stabilization of the transition state has served as the model for calculations linking the role of solvent orientation to the rate of photoinduced electron transfer.⁸² Evidence confirming the dynamic role of solvent in electron transfer has been demonstrated by ESR spectroscopic investigations.^{83,84}

7. Useful Kinetic Relationships Derived from Self-Exchange Electron-Transfer Reactions

Self-exchange electron transfer is defined as a process where electron transfer results in no net chemical change. According to this definition, self-exchange reactions for an excited-state and ground-state reactant take the form^{15,85-87}

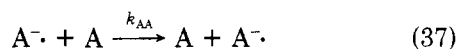
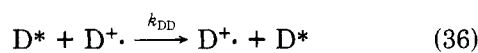

The corresponding cross-reaction is given by

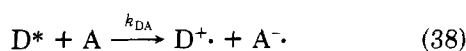

Since self-exchange electron transfer involves no overall change in the overall free energy ($\Delta G = 0$), the activation barriers can be expressed in terms of the intrinsic barrier; i.e., from eq 33, $\Delta G^\ddagger = \lambda/4$ for reactions 36 and 37. The intrinsic barrier for the cross-reaction can be approximated as the average of the individual intrinsic barriers of the self-exchange reactions:

$$\lambda = \frac{1}{2}(\lambda_{DD} + \lambda_{AA}) \quad (39)$$

Substitution of eq 39 into eq 33 gives the following relationship:

$$\Delta G_{DA}^\ddagger = \frac{1}{2}(\Delta G_{DD}^\ddagger + \Delta G_{AA}^\ddagger) \left(1 + \frac{\Delta G_{AA}^\ddagger}{2(\Delta G_{DA}^\ddagger + \Delta G_{AA}^\ddagger)} \right)^2 \quad (40)$$

From eq 40, we can derive

$$k_{DA} = k_{et} = (k_{DD}k_{AA}K_{DA})^{1/2} \quad (41)$$

where K_{DA} is the equilibrium constant for the cross-reaction. Equation 41 holds when $\Delta G_{DA} \sim 0$ and is of practical importance in that it allows for calculation of

TABLE VI. Representative Rates of Electron Self-Exchange and Cross Reactions

redox couple	rate constant, $M^{-1} s^{-1}$
$Ru(bpy)_3^{2+/3+}$	4.2×10^8 ^a
$Ru(bpy)_3^{2+*/3+}$	$\sim 10^8$ ^b
$Fe(aq)^{2+/3+}$	~ 4 ^a
$Cr(bpy)_2^{2+*/2+}$	$\sim 10^8$ ^b
$Cu(dpp)_2^{1+*/2+}$	$\sim 10^8-10^9$ ^c
$V(aq)^{2+/3+}$	$\sim 10^{-2}$ ^b
naphthalene ^{0/-}	$\sim 10^8$ ^d
nitrobenzene ^{0/-}	3×10^7 ^d
<i>N,N,N',N'</i> -Tetramethyl- <i>p</i> -phenylenediamine ^{0/-}	$1.1 \ll \text{tem } 10^9$ ^d

^aFrom ref 77 and references therein. ^bFrom ref 26 and references therein. ^cFrom ref 238. ^dFrom ref 79 and references therein.

the rate of electron transfer, k_{et} . K_{DA} can be obtained from redox potential data. Representative values of the rates of self-exchange electron transfer for ground-state and excited-state reactants are listed in Table VI. It should be noted that the range of rate constants represents varying contributions from bond length changes and solvent reorganization. Thus, the rate of $Ru(bpy)_3^{2+}-Ru(bpy)_3^{3+}$ self-exchange is determined by solvation effects because no changes in bond lengths take place during self-exchange of an electron. Self-exchange between $Fe(H_2O)_6^{2+}$ and $Fe(H_2O)_6^{3+}$ is slow because of barriers due to both solvent and bond reorganization.

Equation 41 can also be used to calculate self-exchange rate constants when k_{et} is known. Values of k_{et} can be derived from a knowledge of $k_{diff} \sim 10^{10} M^{-1} s^{-1}$ and k_q , which is determined from quenching studies.

8. Summary of Electronic and Nuclear Effects in Electron Transfer and Their Role in Energy Transfer

After the nuclear changes bring the entire system to the distorted geometry most suitable for electron transfer, the transfer of the electron creates a state with the electronic configuration of the products but the nuclear geometry of the transition state (Figure 11). Nuclear relaxation follows, bringing the distorted nuclear structure to the equilibrium and thermally equilibrated state of the products. The nuclear barriers for the quenching of excited states by electron transfer can be classified as due to solvent reorganization or to bond length changes, although much remains to improve upon our understanding of the nature of these changes. As we have shown, Marcus theory provides a quantitative formalism to examine these configurational changes.

Table VII summarizes the important features of nuclear and electronic barriers as they influence reactivity

TABLE VII. Summary of Electronic and Nuclear Barriers in Photosensitized Electron Transfer

	$\Delta G^* \sim 0 \langle \chi_i / \chi_f \rangle \neq 0^a$	$\Delta G^* > 0 \langle \chi_i / \chi_f \rangle \geq 0^a$	$\Delta G^* \gg 0 \langle \chi_i / \chi_f \rangle = 0^a$
$k = 1 \langle \Psi_i / H / \Psi_f \rangle \neq 0^b$	strongly adiabatic; resonance important; Marcus theory breaks down; exciplex pathway		
$k \leq 1 \langle \Psi_i / H / \Psi_f \rangle \neq 0^b$		weakly adiabatic; nuclear reorganization important; electronic effects not rate determining	weakly adiabatic; rate is slow because of large nuclear barriers; nuclear tunneling possible
$k \ll 1 \langle \Psi_i / H / \Psi_f \rangle \sim 0^b$	nonadiabatic; slow because of poor orbital overlap; electron can tunnel through barrier		nonadiabatic; slow because of electronic and nuclear barriers; electron and nuclear tunneling possible

^aOverlap of nuclear wave functions. ^bOverlap of electronic wave functions.

in electron-transfer quenching. One important consideration is that the lifetime of the excited reactant imposes a restriction on nuclear reorganization and electronic coupling. Bond length changes, solvent reorganization, and dynamic molecular motions necessary for orbital overlap must occur during the lifetime of the excited state of the sensitizer. Electron transfer is therefore highly sensitive to the photophysical properties of the sensitizer. In turn, these will affect competitive pathways, e.g., energy transfer.

How do the barriers in electron transfer compare with those in energy transfer? As in the case of electron transfer, energy transfer by electron exchange depends upon effective overlap between electronic and vibrational wave functions.⁷ An interaction energy can be defined for energy transfer, analogous to the treatment employed for electron transfer.⁸⁸ The electronic barrier for electron-exchange energy transfer may in fact be greater than for electron transfer, since collisional energy transfer requires the overlap of two orbital pairs of the donor and acceptor for the electron-exchange mechanism.⁸⁹ The effect of distance on the rate of electron exchange in energy transfer can be described by eq 30; i.e., the rate of electron exchange is predicted to decrease exponentially with distance in much the same way predicted for electron transfer.⁹⁰

Reorganizational nuclear barriers in energy transfer reflect predominantly intramolecular vibrations. Solvent reorganization is not expected to have the same importance in energy transfer, since normally changes in charge distribution in the reactants do not occur during energy transfer, unless the reactant molecules have ionic character.

9. The Relationship between Driving Force and Free Energy of Activation

Equation 33 predicts a parabolic relationship between the free energy of activation and thermodynamic driving force of electron transfer. The consequence of this prediction is that the rate of electron transfer should increase as the reaction becomes more exothermic until a certain value of ΔG is reached where the rate begins to fall again! The range of free energy values where the rate increases with increasing driving force is known as the "normal" free energy region (Figure 12). A plot of ΔG vs. ΔG^* in the "normal" region gives a slope of 0.5 (from eq 33).^{15,26} The very negative free energies where the rate is predicted to diminish has been described as the Marcus "inverted" region.

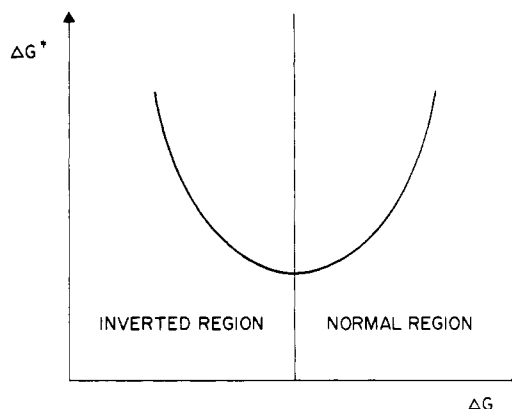

Figure 12. The relationship between ΔG and ΔG^* . The inverted region is one of the predictions of classical and nonclassical theories of electron transfer.

Potential energy curves depicting this rather extraordinary prediction are shown in Figure 13. The disposition of potential energy curves predicted for $\Delta G = 0$ is illustrated in Figure 13a. An example of the "normal" region is given by Figure 13b. From the latter figure, we predict the usual correlation between driving force and the energy barrier. The rate maximizes for the overlapping energy curves shown in Figure 13c. As the free energy proceeds to more negative values, the energy of activation should begin to increase again (Figure 13d).

The same prediction follows from theories of radiationless transitions (the "energy gap" rule).^{91,92} At small energy separations (Figure 13a-c), quantum mechanical treatments predict that the rate should be influenced by coupling of nuclear wave functions rather than overlap of orbital wave functions ($H_{ij} > 0$). Thus, the "nonclassical" counterpart of Marcus theory is that the overlap of nuclear wave functions guarantees a crossing at the intersection of the curves. At large energy separations, however, the electronic and nuclear overlap are unfavorable. Crossing is nonadiabatic and forbidden by Franck-Condon factors; i.e., vibrational overlap is poor at the intersection point.

Under conditions where there is poor overlap between the electronic and nuclear wave functions, tunneling between the initial and final states can create an alternate pathway for the electron-transfer reaction, provided that the available thermal energy does not exceed the potential energy of the electronic and nuclear barriers.^{66,67} Tunneling through electronic and

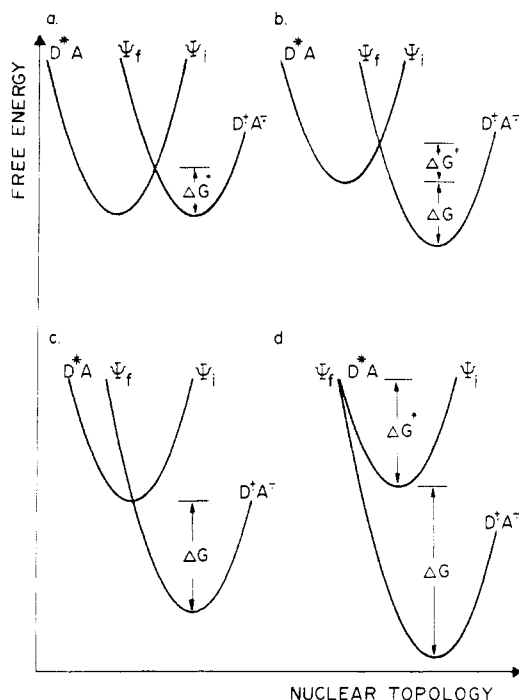

Figure 13. Free energy relationships in photosensitized electron transfer. (a) $\Delta G = 0$; $\Delta G^* = \lambda/4$; $\langle \Psi_i/H/\Psi_f \rangle \neq 0$; and $\langle \chi_i/\chi_f \rangle = 0$. (b) $\Delta G > -\lambda$; $\Delta G^* > 0$; $\langle \Psi_i/H/\Psi_f \rangle \neq 0$; and $\langle \chi_i/\chi_f \rangle > 0$. (c) $\Delta G = -\lambda$; $\Delta G^* = 0$; $\langle \Psi_i/H/\Psi_f \rangle \neq 0$; and $\langle \chi_i/\chi_f \rangle \neq 0$. (d) $\Delta G < -\lambda$; $\Delta G^* \gg 0$; $\langle \Psi_i/H/\Psi_f \rangle = 0$; and $\langle \chi_i/\chi_f \rangle = 0$. $\langle \Psi_i/H/\Psi_f \rangle$ and $\langle \chi_i/\chi_f \rangle$ are the electronic and nuclear matrix elements, respectively. Cases a–c show free energy relationships for electron transfer in the normal region. The last case pertains to electron transfer in the inverted region.

nuclear barriers can be considered possible pathways, since there is always residual overlap between even poorly overlapping wave functions. The physical consequence of tunneling through electronic or nuclear barriers is that at low temperatures, in viscous media, or in rigid molecular systems, electron transfer may be more rapid than would normally be expected from a consideration of the height of the energy barrier.

An experimental manifestation of the inverted region is an inverse relationship between $\log k_q$ and ΔG at large thermodynamic driving forces.²⁸ Experimental evidence of the inverted region in electron transfer has been difficult to obtain because of the “masking” effect of k_{et} by k_{diff} in diffusion-controlled quenching (see eq 25 and 26).⁹³

Weller has determined that for $\Delta G < 10$ kcal/mol, the magnitude of the fluorescence quenching rate constant is diffusion-controlled ($k_q = 2 \times 10^{10}$) for many organic reactants and remains constant as ΔG becomes more negative.⁴² For these systems, k_q can be calculated from an empirically derived expression:

$$k_q = \frac{20 \times 10^9 \text{ M}^{-1} \text{ s}^{-1}}{1 + 0.25[\exp(\Delta G^*/RT) + \exp(\Delta G/RT)]} \quad (42)$$

Other explanations for the lack of an “observable” inverted region have been proposed. For example, nuclear tunneling through the large free energy barrier predicted at large driving forces results in a faster reaction than normally calculated for the height of the barrier.⁹³ Another factor is that a new mechanism may be lurking at large driving forces; e.g., electron transfer may result in electronically or vibrationally excited states.⁴²

Nevertheless, possible evidence of the inverted region has been demonstrated for intramolecular electron transfer between donor–acceptor pairs held by rigid spacer molecules undergoing bombardment by an electron beam:⁹⁴

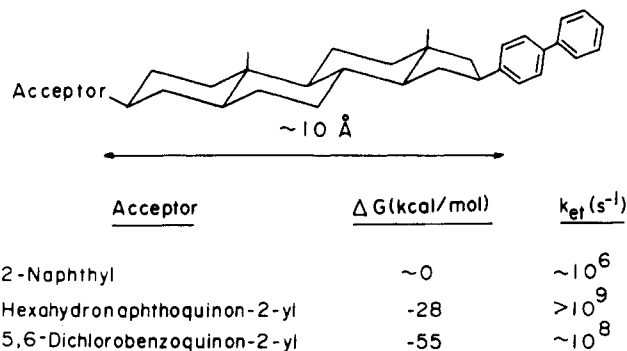

If the donor (D) = biphenyl and various acceptor groups are substituted, the rate of electron transfer varies with the driving force in a manner predicted by eq 33. If the Marcus prediction holds, studies on systems similar to that shown above should uncover other examples of the inverted region.

It is interesting to note that inverted relationship is predicted by the energy gap rule to apply energy transfer. For example, the rate of energy transfer by the dipole–dipole and electron-exchange mechanism can be treated in terms of the spectral overlap between donor emission and acceptor absorption,⁷

$$J = \int f_D f_A d\nu \quad (43)$$

where J is the spectral overlap integral and f_D and f_A are the spectral distribution of the donor emission and acceptor absorption integrated over a range of wavenumbers, J is analogous to the vibrational overlap required for electron transfer. The value of J is reduced when the acceptor’s excited state is much higher than the donor’s emission; i.e., the donor’s emission is well separated from the acceptor’s absorption spectrum.

A possible example of an inverted region in energy transfer has been suggested by the fluorescence quenching of a series of aromatic donor molecules by 2,3-diazabicyclo[2.2.1]hept-2-ene:⁹⁵

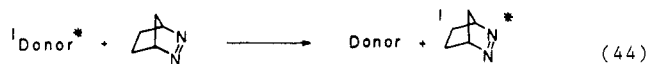

Donor	ΔE (kcal/mol)	k_f (M ⁻¹ s ⁻¹)
Chrysene	5	~10 ⁷
Phenanthrene	1	10 ⁹ - 10 ¹⁰
Naphthalene	-8	~10 ¹⁰
Benzene	-26	10 ⁹ - 10 ¹⁰

$$\Delta E = E_S(\text{Acceptor}) - E_S(\text{Donor})$$

The rate of fluorescence quenching is slow for aromatic sensitizers with singlet energies less than the singlet energy of the azo quencher ($E_s = 84$ kcal/mol). The rate is maximum when the sensitizer is naphthalene ($E_s = 92$ kcal/mol) and the overlap between naphthalene’s emission and the quencher’s absorption is maximized. A falloff in rate occurs with sensitizers of higher electronic energies than that of naphthalene, e.g., benzene ($E_s = 110$ kcal/mol).

It is interesting to speculate on the consequences of free energy differences in systems where both energy and electron transfer can take place. We can reasonably predict that these pathways may coexist, if sensitizers of high electronic energies are employed and if their redox potentials are compatible with large driving forces of electron transfer for given quenchers. If one pathway is forbidden because of a large free energy gap, will the other be observable? What are the nature of the nuclear barriers of electron transfer and electron exchange at large driving forces? One would expect solvent reorganization to dominate electron transfer and bond reorganization to influence electron exchange, but this question has not been explored.

10. The Role of Entropy

The nuclear and solvent arrangements in the initial, intermediate, and final stages of electron transfer may be expressed within the framework of entropy changes.⁹⁶ Each state consists of a large number of quantum states, each representing a specific order or geometry. The entropic differences between these states are determined by the quantum spacings and the probability that the quantum states can be occupied; i.e., if the energy spacing between the quantum states is small, then the probability that many of them will be occupied is high.

Transitions may involve any of these quantum states during the course of electron transfer. If, for example, the transition state for electron transfer consists of widely spaced quantum states, each with a unique geometry, it is likely that only those quantum states with the lowest energies will be occupied. Such a transition state will be highly ordered. Let us consider two uncharged reactant molecules in a highly polar medium. Initially, the reactant state is disordered since the solvent molecules are not arranged in any particular orientation. After charge develops on the reactants, the polar solvent molecules in the surrounding solvent shells adopt specific orientations for charge stabilization. This is equivalent to a "freezing" of the transition state and results in a negative entropy of activation. Solvent molecules can also rearrange around the final ionic products, resulting in an overall negative entropy change. Given this simple conceptual role of entropy, we can envision electron-transfer reactions being "driven" by entropic changes.

11. Outer-Sphere and Inner-Sphere Electron Transfer

The pioneering experiments of Taube and his associates established the distinction between "outer-sphere" and "inner-sphere" electron transfer.^{12,13,97} This classification was originally applied to electron transfer between ground-state metal complexes. Each pathway is defined in terms of the changes that the coordination spheres or surrounding ligands of the metal ions experience during oxidation and reduction. In outer-sphere electron transfer, the inner coordination sphere remains intact and no metal-ligand bonds are made or broken during the reaction. Metal-ligand bonds may undergo distortions, however, and thereby contribute to the overall nuclear reorganization.

In inner-sphere electron transfer, the electron transfers through a bridging ligand which covalently

links the metal centers. Metal-ligand bond breakage and formation do not actually take place synchronously with electron transfer. The metals need not be linked permanently; all that is required is that at some point during the reaction the two metals be bridged by the ligand:

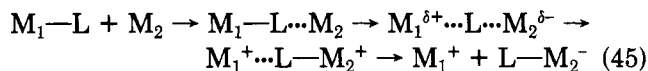

L = π - or σ -bridging ligand

The strong coupling induced by the bridging ligand can enhance the rate of electron transfer.⁹⁸ The effect of the bridging ligand is to alter the energy levels of the donor and acceptor orbitals or to serve as a "conduit" for the passage of the electron, whether the electron is transferred directly or by sequential hopping.¹³

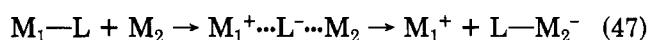
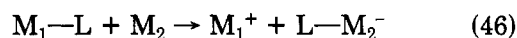

A ligand of appropriate symmetry can thus enhance the adiabaticity of electron transfer by increasing the magnitude of the electron interaction term.

The concept of outer- and inner-sphere electron transfer is applicable to photosensitized electron transfer. Any molecular unit that links a donor-acceptor pair and transmits the electron is the "photochemical equivalent" of the bridging ligand in an inner-sphere reaction. This is actually a case of through-bond coupling. Examples of systems where a through-bond interaction is possible (although at this stage not necessarily proven) are considered in section IV.B.3.

D. Pathways of Secondary Electron Transfer

In a typical electron transfer photosensitized reaction, the pathway from the initial interaction between the reactants to products is an energetically "downhill" process. The excited-state molecule and quencher may "explore" several reaction channels before selecting one with the smallest energy barrier. The combined energy content of the radical ion pair lies below the combined energy of the reactants. As the reaction proceeds, new intermediates are successively generated, and the energy content of each pair continues to drop until stabilized radical ions are formed.

The reactions that proceed from the radical ion pair intermediates are collectively classified as secondary electron-transfer processes and include formation of stable products, ground-state electron transfer including return to singlet state reactants, and reversible triplet recombination to form triplet states of one of the reactants. Product formation may take place by simple radical ion coupling or by a series of ground-state electron-transfer reactions, including sensitization, cosensitization, and chain pathways. These possibilities are exemplified in Scheme IV and Figure 14.

In photosensitized electron transfer, the photosensitizer is normally regenerated after a series of ground-state electron transfers. The efficiency of these reactions depends to a large degree upon the rate of return to ground-state reactants after initial formation of the radical ion pair. If the components of the radical

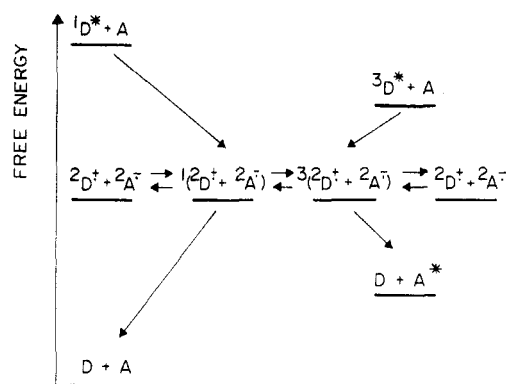

Figure 14. Spin dynamics in electron transfer. Spin is conserved during electron transfer. Intersystem crossing following electron transfer may generate radical ions of opposite overall spin. Radical ions "lose" their spin correlation after separation from the solvent cage.

ion pair are generated in close proximity, return can be rapid, unless solvent forces can quickly penetrate the space between the ions and stabilize the formation of free ions. The rate constant for dissociation of the exciplex into radical ions ranges from $5 \times 10^8 \text{ s}^{-1}$ in polar solvents to less than 10^6 s^{-1} in nonpolar solvents.⁹⁹

Return to ground state can also be retarded because of the energy spacing between radical ion pair and reactants.²⁶ From the energy gap rule, the rate will be slow if a fairly large spacing separates these energy states.^{1,26} Another method of preventing return to ground state involves the use of appropriate scavengers.²⁷ A scavenger molecule can be employed to effectively trap one of the radical ions. This method has found application in solar energy storage systems.²⁸

To understand the importance of triplet recombination, one must consider the spin states of the geminate radical ion pairs formed immediately after electron transfer. These states reflect the spin states of the excited-state partner. Thus, the quenching of a singlet or triplet sensitizer by a ground-state molecule produces a correlated singlet or triplet radical ion pair, respectively. The spin-correlated states can also be formed by hyperfine- and spin-orbital-induced intersystems crossing subsequent to the generation of the radical ion pairs.⁹⁹⁻¹⁰¹ According to Figure 14, the pathways available to a correlated singlet pair include intersystems crossing to a triplet pair, diffusion from the cage into the bulk of the solution (where the radicals lose their correlation), and singlet recombination by reversible electron transfer. The latter pathway is spin-allowed and rapid and can be a particularly undesirable energy-wasting reaction. Recombination of a triplet radical ion pair to generate singlet products is spin-forbidden. Diffusion from the cage is more likely.

Free ions in bulk solution are uncorrelated, but they may collide to produce singlet or triplet ion pairs. The statistical probability of generating singlet and triplet pairs from random spin states is 25% and 75%, respectively. Recombination of radical ions in bulk solution generally occurs on the order of microseconds after their initial formation, as compared to several nanoseconds for ionic recombination within a cage.

Triplet recombination must be considered when the combined energy of the radical ion pair lies lower than the triplet energy of one of the reacting partners. The energy gap rule indicates that the triplet state of that

reactant lying closer to the energy of the ion pair is preferentially populated. Eventually the triplet state may undergo a chemical change or decay to ground state.

The net change in triplet recombination is formally singlet-triplet energy transfer, since the triplet state of the quencher is eventually populated. The detailed pathway in triplet recombination is a series of two electron transfers which, as has already been shown (Figure 1), are conceptually equivalent to one electron exchange in two directions. However, the initial step involves the generation of a radical ion pair, which is the distinguishing feature of quenching by electron transfer. In polar solvents, solvation can stabilize the ions and result in competing electron and energy transfer pathways (section IV.C.3).

III. Experimental Evidence for Electron Transfer

A variety of methods have evolved for establishing whether photosensitized reaction involves energy or electron transfer.^{1,102} This section presents an overview of these methods and a discussion of some of the pitfalls. Many of these procedures are general techniques for determining any reaction mechanism. These will not be discussed in as much detail as the methods which are specific for photosensitized electron and energy transfer.

A. Energetics

1. Redox Potentials and the Weller Equation

The first step in determining the feasibility of an electron-transfer pathway for a bimolecular quenching reaction should involve an evaluation of the free energy changes.⁴² Equation 16 can be used for this calculation. The parameters in eq 16 are easily obtained from simple measurements^{82,102,103} or the literature values.^{18,19,42,104} Since both excited-state energies and redox potentials can change with solvent, it is a recommended practice to use values obtained in the same solvent. In polar solvents or in cases where the ions diffuse apart, the Coulombic term can be ignored as a first approximation (eq 17).

Equations 16 and 17 state that the energy of the excited state must be higher than the energy required for oxidation or reduction of the donor and acceptor for exothermic electron transfer. In some cases, electron transfer may be energetically feasible for one excited state and not feasible for the other spin state if the latter is of lower energy.

2. Electronic Energy Levels

To exclude energy transfer, one must consider the excited-state electronic energies of the donor and acceptor.^{1,105} If the energy of the acceptor exceeds that of the donor by 3 or more kcal/mol, then energy transfer will be inefficient.^{1,5,7} Excited-state energies for many organic and inorganic compounds are known.^{5,18,19,104,105} In other cases, the values can be determined spectroscopically from the onset of longest wavelength absorption or from emission spectroscopy.

If the donor excited-state energy is greater than the acceptor excited-state energy, the rate constant for energy transfer will be diffusion-controlled unless spin selection rules or steric hindrance are involved. When considering possibility of energy transfer, one must recall that conservation of spin must be observed. For example, an excited singlet state donor cannot normally transfer energy into the triplet state of a quencher even though the triplet state is of lower energy.¹

3. Quenching Rate Constants vs. the Driving Force of Electron Transfer

For quenching by electron transfer, the rate constant can be related to the free energy calculated from the Weller equation, if one assumes that the free energy of activation is a continuous function of the driving force (eq 42). The rate constants for a series of reactions where one excited state is quenched by related quenchers can be plotted against the free energies of the reactions.^{42,106,107} If a plot of $\log k_q$ vs. the redox potentials or ΔG yields a straight line which levels off at diffusion-controlled rates, then this can be taken as strong evidence for an electron-transfer mechanism.^{29,108} The slope of the straight line should equal $1/RT$ (see eq 42).¹⁰⁸ Data which do not fit such a plot do not necessarily indicate that the reaction is by energy transfer, since steric effects or pathways involving exciplexes can alter the rate constants.¹⁰⁹

B. Detection of Intermediates

1. Flash Photolysis Detection

In many instances, the short-lived transients formed during a photochemical reaction can be observed spectroscopically by flash photolysis.^{110,111} A pulse of light from a lamp or laser generates the intermediates, which can be detected by absorbance, fluorescence, resonance Raman, or conductivity. In flash photolysis, the pulse can be as long as milliseconds or as short as picoseconds. In general, the lifetime of the transient must be longer than the pulse width of the flash for accurate detection.

UV-vis absorption to detect transients in flash photolysis is the most widely used method.¹¹² Detection systems are set up to measure the change of optical density vs. time at a fixed wavelength. A transient spectrum can be obtained by plotting intensity of the signal vs. monitored wavelength. Transient absorption can be measured instantaneously with an optical multichannel analyzer.¹¹¹ The transient spectra obtained in this way can be compared to known spectra of cation radicals or anion radicals or excited-state absorption spectra.^{113,114}

Many ion radicals generated by photosensitized electron transfer will fluoresce if excited by light after the initial pulse.¹¹⁵ The fluorescence spectra of the transient can be compared to known spectra.

Resonance Raman is a fairly recent technique for observing transients.¹¹⁶ An enhanced Raman signal is obtained if the probing light coincides with an absorption band of the transient. Although resonance Raman spectroscopy is not as sensitive as absorption spectroscopy, it yields considerably more detail about the transient structure. It also allows for the observation

of two species with different Raman bands which have overlapping UV-vis absorption spectra.

Transient conductivity can also be used to detect the formation of ions after flash photolysis.^{117,118} Any electron-transfer process that produces cation and anion radicals will increase the conductivity of the solution. This technique is sensitive especially compared to resonance Raman and UV-vis spectroscopy.²¹ However, little information about the structure of the ion radicals can be obtained.

In utilizing flash photolysis, one can measure the formation or decay of the transient signal as a function of time. From this data the kinetics of electron transfer or the reactions which lead to the disappearance of the transient species can be determined.¹¹⁹ Under ideal conditions, one can observe the decay of the excited state involved in electron transfer with the concomitant increase in both the cation and anion radical. One may be able to follow the decay of each species separately. This procedure can be particularly useful for obtaining the details of a reaction mechanism.^{120,121} There are several cases where the excited state and the ion radicals each have different absorption spectra.^{122,123}

2. ESR/Spin Traps

Electron spin resonance (ESR) can be used to detect the presence of ion radicals resulting from quenching electron transfer.^{124,125} Irradiation in an ESR cavity can lead to a steady-state concentration of ion radicals whose ESR spectra can be evaluated. Lowering the temperature of the sample can increase transient lifetimes long enough so that detection is possible ($\tau > 100 \mu\text{s}$).¹²⁴ In cases where the ion radicals are too short-lived for detection, spin traps can be employed.^{126,127} The spin traps react with the radicals to give more stable radicals. The ESR spectrum for a given spin-trapped radical can be used to identify the structure of the initially formed radical. Transient ESR using a pulsed light source for generating radicals has been used recently.^{111,128,129} From this type of experiment, the kinetics of ion radical formation and disappearance can be measured.

3. CIDNP

Chemically induced nuclear polarization (CIDNP) is a nuclear magnetic resonance technique where large enhanced signals (either positive or negative) are observed when radical and ion radical pairs are formed.^{11,130,131} When ion pairs are generated photochemically by electron transfer in an NMR cavity, the spin multiplicity of the ion pair will be the same as the initial excited state. If escape from the cage is competitive with a change in spin multiplicity of the ion pair, then enhanced signals may be observed in the NMR spectra of the products.¹³² The direction of the NMR signals is dependent on a complex relationship involving the spin multiplicities of the excited state and ion pairs, hyperfine coupling constants, and the states from which the products are formed (i.e., "in-cage" or free ions). The dynamics of electron transfer can often be traced from the observed polarization in reactants and products by application of a set of rules.¹³¹⁻¹³³

Most CIDNP experiments use a steady-state light source; however, a laser pulse can also be used to obtain

transient CIDNP spectra.¹³⁴ The data obtained from the transient CIDNP spectra can be related to the kinetics of the reaction.

4. Luminescence

In energy transfer a new excited state is generated which may have a different fluorescence or phosphorescence than the initial excited state.¹³⁵ Observation of this new emission is good evidence for energy transfer. Using fluorescence lifetime techniques (e.g., single photon counting), one can measure the increase in intensity of the fluorescence after the lamp pulse. Such an observation indicates that the new excited state was formed by energy transfer. From the lifetime data, the rate of energy transfer can be calculated. Conclusions based on observed luminescence, however, should be reached cautiously since triplet recombination of ions generated by electron-transfer quenching can also lead to emission.¹³⁶

5. Further Studies of Intermediates

It must be emphasized that the lack of an observation of charge-transfer transients cannot be used to rule out electron transfer. The transients may be difficult to detect because of a lack of knowledge of the spectral patterns, poor sensitivity, or a short lifetime due to rapid decay processes. In addition, the detection of a charge-transfer transient does not prove an electron-transfer mechanism. The formation of that transient can be a side pathway which may not be involved in product formation. CIDNP is especially prone to misdiagnosis because of intense signals for minor pathways.

There are several ways to improve upon the evidence for charge-transfer transient involvement. For example, a substrate that quenches a transient should also inhibit product formation if the same mechanism is operating. This quenching process can be observed by either a decrease in the transient signal intensity or lifetime. It is helpful to understand the nature of the quenching process since there is the possibility that a substrate can quench several pathways at the same time.

Another method to verify the involvement of ionic species is to measure quantum yields.¹³⁷ A comparison of the quantum yield for product formation and for charge-transfer transient formation can often indicate if the two processes are related. For example, if the quantum yield for both product formation and transient formation exceeds 0.5, then the transient must be involved in the mechanism, provided that the maximum quantum yield is 1.0. If the quantum yield for transient formation is less than that for product formation, then the transient is not involved in the reaction. These statements, of course, are only valid if the quantum yields for transient formation are accurate. Accurate measurements of quantum yields can in fact be quite difficult.

C. Product Studies

1. Scavengers of Intermediates

One method of identifying intermediates is to trap or scavenge them with an appropriate compound.^{138,139}

The products can then be analyzed by standard methods. In many cases, it is possible to find specific scavengers for cation radicals, anion radicals, or excited states.

2. Structure of Products

The structure of the products can indicate the nature of the mechanism. For example, methanol adds to photochemically produced olefin cation radicals by an anti-Markovnikov addition.^{140,141} As shall be demonstrated with specific examples in section IV.C, this is good evidence for generation of the olefin cation by electron-transfer quenching. Rearrangements or loss of optical activity which normally can be observed exclusively from radical ions and not excited states can also be used to support electron transfer.^{142,143}

3. Generation of Intermediates

Nonphotochemical methods are available to generate the various intermediates which may be present in a photochemical reaction.^{103,111,112} If the intermediate leads to the same product as the photochemical process, then this is strong evidence for its involvement in the reaction. Radical ions, for example, can be generated electrochemically.¹⁰³ Generation of both the cation and anion radicals in the same solution is experimentally difficult.

D. Kinetics

1. Quenching Studies

The kinetics of product formation can be useful in determining the mechanism of a photochemical reaction. In some cases, the kinetics can help to eliminate several mechanisms under consideration.¹⁴⁴ Usually, this will not help to differentiate between electron and energy transfer. However, the effect of adding various compounds on the kinetics can make this distinction. In general, one should select a substrate which quenches only one of several possible intermediates. Quenching of an important intermediate will lead to a decrease in rate of product formation and therefore a lower quantum yield.¹⁴⁵ The most difficult part of this procedure is the need to verify that the quencher is not affecting other possible intermediates.¹⁴⁶

2. Magnetic Field Effects

In electron-transfer processes where radical ion pairs are formed, magnetic fields may influence the quantum yield of radical ion pair formation.^{147,148} In particular, a magnetic field can decrease the rate of conversion of spin multiplicity of radical pairs (section IV.B.2). If conversion is an important aspect of product formation, a magnetic field effect may be observed. An example is described in section IV.B.2.

E. The Effect of Solvent Polarity

The nature of the medium can have an important influence on the rate of photochemical reactions. This is especially true for electron-transfer processes that lead to the generation or disappearance of polar spec-

TABLE VIII. Minimum Lifetimes^a of Sensitizer at Given Concentrations of Quencher Required to Quench about 50% of Sensitizer

$k_{et}, M^{-1} s^{-1}$	[quencher], M		
	1.0	10^{-3}	10^{-6}
10^5	10^{-5}	10^{-2}	10
10^9	10^{-9}	10^{-5}	10^{-3}
10^{11}	10^{-11}	10^{-8}	10^{-5}

^a In s.

ies.²⁰ As described in section II, one can expect a strong solvent influence on the quantum yield of photosensitized electron transfer. For example, ionic products are usually formed in polar solvents.¹⁴⁹⁻¹⁵² It is for this reason that the majority of photosensitized electron-transfer processes have been investigated in polar solvents, such as acetonitrile. Energy-transfer reactions can be dependent on solvent polarity since polarity can affect both excited-state energies and lifetimes, but in most cases these effects are minimal (section II.B.4).

IV. Examples of Electron-Transfer Photosensitization

A. Spectroscopic and Electrochemical Properties of the Sensitizer: Practical Considerations

The selection of a sensitizer with the requisite spectroscopic and electrochemical parameters is crucial for photosensitization by electron transfer. The sensitizer must not only pass the usual "tests" required of a photosensitizer (i.e., it must be the principal light absorbing species, it should not form ground-state complexes with the quencher, and its lifetime must be sufficiently long), but its redox potentials should also be compatible with electron transfer. The energy of the exciting photon must therefore be sufficient to increase the oxidizing or reducing capacity of the sensitizer. It must be remembered that if the singlet- or triplet-state energy of the sensitizer exceeds the electronic energies of the quencher, then energy transfer may become competitive. In practical terms, therefore, the sensitizer should absorb at longer wavelengths than the quencher, while at the same time retaining its oxidizing or reducing capacity.

Equation 21 can be used to determine if the lifetime of the sensitizer is sufficient for quenching by electron transfer. The concentrations of the quencher required to quench about 50% of the excited states for typical k_q values are listed in Table VIII ($\phi_{es} \sim 1$ is assumed). Values of k_q ranging from 10^5 – $10^7 M^{-1} s^{-1}$ are typical of "slow" electron transfer; larger values are characteristic of rapid, diffusion-controlled quenching. At both limits, the lifetime of the sensitizer cannot be shorter than those values in Table VIII. A sensitizer with a lifetime as short as 10^{-9} s can be quenched at a diffusion-controlled rate of $\sim 10^9 M^{-1} s^{-1}$ with an efficiency of 50% at [quencher] = 1 M. For a slower reaction, a sensitizer with a longer lifetime may be required to obtain the same efficiency.

The excited-state energies, redox potentials, lifetime data, and intersystems crossing efficiencies are compiled in Tables IX (organic sensitizers) and X (metal complex sensitizers). Redox potentials of typical quenchers are listed in Tables XI and XII. Several guidelines must be observed in using the data in these tables. First, although the singlet states of many sensitizers are more effective in electron-transfer quenching than the respective triplet states, singlet-singlet energy transfer may nevertheless populate lower lying singlet states of the quencher. Second, the singlet states of molecules with short singlet lifetimes and high intersystems crossing efficiency are generally ineffective as singlet electron-transfer sensitizers; their triplet states, however, may be capable of functioning as reducing or oxidizing agents. A notable example is chloranil whose triplet state has a fairly high reduction potential. Third, at lower quencher concentrations, a portion of the singlet-state sensitizers may "escape" quenching and be converted to the triplet state following intersystems crossing. Energy-transfer, electron-transfer, or photochemical reactions may then constitute undesirable side reactions. Intersystems crossing to reactive triplet states can frequently be avoided at higher concentrations. The tradeoff is that ground-state complexation at higher concentrations may have to be taken into consideration.

B. Evidence that Primary Quenching Is via Electron Transfer

1. Quenching of the Excited States of Metal Complexes

Selected examples of quenching by primary electron transfer are explored in this section. We start with quenching of the excited states of metal complexes. The examples that are covered are those which utilize the experimental procedures outlined in section III to establish the quenching mechanism. We will also indicate, when possible, the difficulties in sorting out energy and electron transfer in these systems.

Many experimental lines of investigation have given compelling evidence that the excited states of metal complexes can serve as electron donors and acceptors.^{18,26,27,29,153-156} Metal complexes often show absorption in the visible spectrum, and excitation at these wavelengths results in low energy, long-lived, and in many cases emitting states (Table X). These excited states frequently have sufficiently low oxidation potentials and high reduction potentials to enable them to serve as both electron donors and acceptors. Electron transfer, however, is not always the exclusive quenching pathway; energy transfer has also been documented. It is not trivial to distinguish between the two pathways. Often several experimental approaches must be tried to decide upon the nature of the mechanism. The emphasis in studies on metal complexes is usually on a combination of thermodynamic and kinetic arguments, coupled at times with flash spectroscopy.

a. Ruthenium(II) Tris(bipyridyl) Complexes. $Ru(bpy)_3^{2+}$, a transition-metal d^6 complex, is a particularly instructive paradigm of the effectiveness and versatility of metal complexes as electron-transfer photosensitizers.^{156,157} The quenching reactions of its

TABLE IX. Electrochemical and Photophysical Data of Selected Organic Sensitizers^a

sensitizer	$E(D^{+}/D)$, V ^a	$E(A/A^{-})$, V ^a	$\lambda(o-o)$, nm ^b	E_S , eV ^c	ϕ_f	τ_S , ns ^d	ϕ_{ST}	E_T , eV ^c	τ_T , μ s
acetophenone		-1.85 ^e	363	3.41 (78.7)	0.00		1.0 ^f	3.20 (73.8)	0.41
4-methoxyacetophenone		-1.50 ^e	353	3.51 (81.0)				3.10 (71.5)	
anthracene	1.16 ^g	-1.93 ^e	375	3.31 (76.3)	0.27	5.3	0.72	1.85 (42.7)	500 ^h
9,10-dicyanoanthracene (DCA)		-0.89 ^g	433	2.86 (66) ^g		19.6 ⁱ			
2,6,9,10-tetracyanoanthracene (TCA)		-0.45 ^g	440	2.82 (65.0) ^g		15.2 ⁱ			
<i>p</i> -dicyanobenzene (DCB)		-1.60 ^g	290	4.27 (98.6)		9.7 ^j		3.06 (70.5)	
<i>N,N,N',N'</i> -tetramethylbenzidine (NTMB)	0.32 ^k		345	3.60 (83) ^l	0.30 ^l	10 ^{l,m}	0.63 ^l	2.73 (63) ^l	
methyl <i>p</i> -cyanobenzoate		-1.76 ^g	301	4.12 (95) ^j				3.12 72.0) ^j	
methyl benzoate		-2.29 ^e	280	4.42 (102) ⁿ				3.41 (78.6) ^h	
benzophenone		-1.68 ^o	384	3.23 (74.4)	0.00	0.005 ^f	1.00 ^f	3.00 (69.2)	12 ^f
2,4,6-triphenylpyrillium tetrafluoroborate (TPBF ₄)		-0.29 ^g	440	2.82 (65) ^g				2.30 (53) ^p	
chloranil		0.02 ^q						2.70 (62.3) ^r	4 ^s
chrysene	1.40 ^h		360	3.43 (79.2)	0.12 ^f	43	0.82	2.43 (57.3)	
fluorene	1.55 ^g		301	4.12 (95.1)	0.68	10 ^f	0.32	2.94 (67.9)	
naphthalene	1.60 ⁱ	-2.29 ^h	311	3.99 (92)	0.21	105	0.80, 0.71	2.64 (60.9)	74 ^t
1-cyanonaphthalene (CN)		-1.98 ^g	320	3.88 (89.4) ^j		8.92 ^j		2.49 (57.4) ^j	
1,4-dicyanonaphthalene (DCN)		-1.28 ^g	359	3.45 (79.6) ^j		10.1 ^j		2.41 (55.5) ^j	
2-methoxynaphthalene	1.42 ^u		318	3.90 (90.0)	0.42 ^f	15		2.60 (59.9) ^f	
perylene	0.85 ⁿ		435	2.85 (65.8)	0.87	6.0	0.0088	1.52 (35.1) ^f	
phenanthrene	1.58 ^g	-2.20 ⁿ	345	3.59 (82.9)	0.13	61	0.85	2.69 (62.0)	
pyrene	1.20 ^u		372	3.34 (77.0)	0.53	475	0.38	2.09 (48.1)	
pyrene-3-carboxylic acid		-1.67 ^u	391	3.17 (73.1) ^u		12.5 ^u			
<i>trans</i> -stilbene		-2.26 ^w	304	3.53 (81.4) ^v		0.072 ^{m,u}		2.12 (48.9) ^w	
triphenylene	1.64 ^g	-2.22 ^u	342	3.62 (83.4)	0.07	37 ^f	0.89	2.88 (66.5)	

^a Photophysical data from ref 104, unless otherwise specified; values obtained at room temperature in CH₃CN or other polar solvents, unless indicated otherwise; redox potentials are reported vs. SCE. ^b Onset longest wavelength absorption. ^c Values in parentheses are reported in kcal/mol. ^d Fluorescence lifetimes unless otherwise slated. ^e From Meites, L.; Zuman, P. "CRC Handbook Series in Organic Electrochemistry"; CRC Press: Cleveland, OH, 1976; Vol. 1. ^f In nonpolar solvents. ^g From ref 25. ^h From: Beriman, J. B. "Handbook of Fluorescence Spectra of Aromatic Compounds"; Academic: New York, 1965. ⁱ From: ref 27. ^j From: Arnold, D. R.; Maroulis, A. J. *J. Am. Chem. Soc.* 1976, 98, 5931. ^k From ref 184. ^l From ref 330. ^m Measured singlet lifetime. ⁿ From ref 19. ^o From ref 262. ^p From: Searle, R.; Williams, J. L. R.; DeMeyer; Doty, J. C. *J. Chem. Soc., Chem. Commun.* 1967, 1165. ^q From: Mann, C. K.; Barnes, K. K. "Electrochemical Reactions in Nonaqueous Systems"; Marcel Dekker: New York, 1970. ^r Kasha, M. *Chem. Rev.* 1947, 41, 401. ^s From ref 337. ^t Wilkinson, F.; Dubois, J. T. *J. Chem. Phys.* 1963, 39, 377. ^u From ref 42. ^v From ref 261. ^w From ref 260.

TABLE X. Electrochemical and Photophysical Data of Selected Inorganic Sensitizers^a

sensitizer ^a	$E(D^{+}/D)$, V ^a	$E(A/A^{-})$, V ^a	λ_{max} , nm ^b	E^* , eV ^c	ϕ_e ^d	τ , μ s ^d
Ru(bpy) ₃ ²⁺ ^e	1.29 ^{f,g}	-1.35 ^g	452 ^f (ϵ 10 000)	2.12 (48.9) ^f	0.042 ^h	0.62 ^h 0.85 ^{f,g} 0.49 ⁱ 77 ^f
Cr(bpy) ₃ ³⁺ ^e	>1.6 ^{f,j}	-0.26 ^{f,g}	455 ^f	1.71 (39.4) ^f		<0.002, S ₁ -S ₀ ^l
Rh ₂ (dicp) ₄ ²⁺ ^k	0.89 ^l	-1.4 ^l	553 (ϵ 14 500), S ₀ -S ₀ ^l	1.69 (39), triplet ^l		8.5, T ₁ -S ₀ ^l 0.14 ^m
ReCl ₅ ²⁻	>1.25 ^m	-0.85 ^m		1.75 (40.4) ^m		<0.002, S ₁ -S ₀ ^o
Pt ₂ (P ₂ O ₅) ₄ H ₅ ⁴⁻	<1 ⁿ	-1.4 ⁿ	367 (ϵ 35 000), S ₀ -S ₀ ^o 452 (ϵ 110), S ₀ -T ₁ ^o	2.50 (57.7), triplet ⁿ	0.52, T ₁ -S ₀ ⁿ	9.8, T ₁ -S ₀ ^o 6.6 ^p
UO ₂ ²⁺		0.06 ^f	420 (ϵ 101) ^p	2.54 (58.6) ^p	~1 ^p	0.0014, S ₁ -S ₀ ^r
ZnTMPyP ⁴⁺ ^q	0.94 ^r			2.05 (47.3), singlet ^r 1.57 (36.2), triplet ^r	0.025, S ₁ -S ₀ ^r 0.9, T ₁ -S ₀ ^r	6.55, T ₁ -S ₀ ^r
ZnTPP ^s	0.71 ^{r,u}	-1.35 ^{r,t}	560 ^r	2.05 (47.3), singlet ^r 1.59 (36.7), triplet ^r	0.04, S ₁ -S ₀ ^r 0.88, T ₁ -S ₀ ^r	0.0027, S ₁ -S ₀ ^r 1200, T ₁ -S ₀ ^r
Cu(dpp) ₂ ^{+u}	0.39 ^{v,w}		439 (ϵ 3200) ^x	1.8 (41.5) ^x	~0.0004 ^x	0.310 ^x

^a Data reported at room temperature in aqueous solution, unless otherwise indicated; redox potentials are reported vs. SCE, unless otherwise noted (literature values vs. NHE are corrected). ^b Absorption maximum(a) of lowest energy transition(s). ^c Values in parentheses are reported in kcal/mol. ^d Data pertaining to emitting states. ^e bpy = 2,2'-bipyridine. ^f From ref 18 and references therein. ^g In CH₃CN. ^h From ref 156. ⁱ From ref 159; in CH₂Cl₂. ^j In DMF vs. NHE. ^k dicp = 1,3-diisocyanopropane. ^l From ref 194; in CH₃CN. ^m From ref 197; in CH₃CN. ⁿ From ref 200. ^o From ref 198. ^p From ref 201. ^q TMPyP₄⁺ = tetramethylpyridinium porphyrin. ^r From ref 214 and references therein. ^s TPP = tetraphenylporphyrin. ^t In organic solvents. ^u dpp = 2,9-diphenyl-1,10-phenanthroline. ^v From ref 238. ^w In CH₂Cl₂ vs. ferrocene. ^x Dietrich-Buchecker, C. O.; Marnot, P. A.; Sauvage, J.-P.; Kirchoff, J. R.; McMillin, D. R. *J. Chem. Soc., Chem. Commun.* 1983, 513.

lowest excited state also nicely illustrate a few of the pitfalls associated with experimental approaches designed to study electron transfer.

Its lowest excited state is a metal-to-ligand charge transfer state (d, π^*), formed by promotion of a metal-centered electron (t_{2g}) to a π -orbital of one of the

ligands.^{18,26,154,156-159} It is believed that the electron remains largely localized on only one of the pyridine groups.^{159,160} Although the emitting state really consists of three thermally equilibrated states,¹⁶¹ in practice many models simply assume that these states are indistinguishable (we shall invoke this assumption here).

TABLE XI. Electrochemical and Photophysical Data of Selected Organic Quenchers

quencher	$E(D^+/D)$, V ^a	$E(A/A^-)$, V ^a	E_S , eV ^b	E_T , eV ^b
amines				
<i>N,N</i> -diethylaniline (NDEA)	0.76 ^c		3.90 (90.0) ^d	2.95 (68.0) ^c
<i>N,N</i> -dimethylaniline (DMA)	0.81 ^c		3.85 (88.8) ^e	2.99 (68.4) ^c
diethylamine (DEA)	0.78 ^f		>3.90 (>90) ^g	>3.90 (>90) ^g
triethylamine (TEA)	0.76 ^h		>3.90 (>90) ^g	>3.90 (>90) ^g
triphenylamine (TPA)	0.98 ⁱ			3.04 (70) ^j
1,4-diazabicyclo[2.2.2]octane (DABCO)	0.57 ^h			>3.90 (>90) ^g
<i>N,N,N,N'</i> -tetramethylbenzidine (NTMB)	0.32 ^k		3.60 (83) ^l	2.73 (63) ⁱ
<i>N,N,N,N'</i> -tetramethyl- <i>p</i> -phenylenediamine (NTMP)	0.16 ^m			2.64 (60.9) ⁿ
methoxy compounds				
<i>o</i> -dimethoxybenzene	1.45 ^m			
1,3,5-trimethoxybenzene	1.49 ^m			
2-methoxynaphthalene	1.42 ^m		3.70 (85.3) ^m	1.65 (62) ^p
nitro compounds				
nitrobenzene (NB)		-1.15 ^p	>4.25 (>98) ^j	2.60 (60)
<i>p</i> -dinitrobenzene (DNB)		-0.69 ^r		
cyano compounds				
<i>p</i> -dicyanobenzene (DCB)		-1.64 ^m	4.27 (98.6) ^s	3.06 (70.5) ^s
1,4-dicyanonaphthalene (DCN)		-1.28 ^r	3.45 (79.6) ^s	
tetracyanoethylene		0.24 ^m		
viologens				
methyl viologen (MV ²⁺)		-0.45 ^t		3.10 (71.5) ^t
quinones				
<i>p</i> -benzoquinone		-0.51 ^t		~2.3 (~53) ^u
chloranil (CA)		0.02 ^s		2.70 (62.3) ^v
olefins and cyclic molecules				
1,1-diphenylethylene (1,1-DPE)	1.52 ^w		4.25 (97.9) ^x	
indene	1.23 ^y		>4.2 (>97) ^x	2.60 (60) ^{aa}
norbornadiene	1.54 ^{bb}		>4.3 (>100) ^j	3.0 (70) ^{cc}
quadricyclane	0.91 ^{bb}			~3.5 (~80) ^{dd}
hexamethylbicyclo[2.2.0]hexa-2,5-diene (hexamethyl Dewar benzene)	-1.5 ^{ee}			
dimethylbicyclo[2.2.1]hepta-2,5-diene-2,3-dicarboxylate		-1.67 ^{ff}		2.30 (53) ^{gg}
miscellaneous				
oxygen		-0.78 ^s	0.98 (22.5), ¹ Δ ^{hh}	

^a Redox potentials are reported vs. SCE in polar solvents, unless otherwise noted. ^b Values in parentheses are reported in kcal/mol. ^c From ref 197 and references therein. ^d Beens, H.; Weller, A. In "Molecular Luminescence"; Lim, E. C., Ed.; Benjamin: New York, 1969. ^e From ref 263. ^f Knibbe, H.; Rehm, D.; Weller, A. *Ber. Bunsenges. Phys. Chem.* 1968, 72, 257. ^g Muto, Y.; Nakato, Y.; Tsubomura, H. *Chem. Phys. Lett.* 1971, 9, 597. ^h From ref 260. ⁱ From ref 103; in THF. ^j From ref 102 and references therein. ^k From ref 184. ^l From ref. 330. ^m From ref 42. ⁿ From ref 331. ^o From ref 340. ^p From ref 103. ^q Lewis, G. N.; Kasha, M. *J. Am. Chem. Soc.* 1944, 66, 2108. ^r Maki, A. H.; Geske, D. H. *J. Am. Chem. Soc.* 1961, 83, 1852. ^s From ref 25 and references therein. ^t From ref 318. ^u Beck, S. M.; Brus, L. E. *J. Am. Chem. Soc.* 1982, 104, 1103. ^v Kasha, M. *Chem. Rev.* 1947, 41, 401. ^w Eriksen, J.; Foote, C. S. *J. Phys. Chem.* 1978, 82, 2659 and references therein. ^x From ref 139. ^y From ref 325, vs. Ag/Ag⁺. ^z Friedel, R. A.; Orchin, M. "Ultraviolet Spectra of Aromatic Compounds"; Wiley: New York, 1951; estimated from onset of longest wavelength absorption; in ethanol. ^{aa} From ref 3229. ^{bb} From ref 336 and references therein. ^{cc} From ref 335 and references therein. ^{dd} From ref 339. ^{ee} Roth, H. D.; Schilling, M. L. Mm.; Raghavachari, K. *J. Am. Chem. Soc.* 1984, 106, 253. ^{ff} From ref 342; vs. Ag/Ag⁺. ^{gg} From ref 341. ^{hh} From ref 1 and references therein.

TABLE XII. Electrochemical and Photophysical Data of Selected Inorganic Quenchers

quencher	$E(D^+/D)$, V ^a	$E(A/A^-)$, V ^a	E^* , eV ^b
metal complexes			
Ru(bpy) ₃ ²⁺	1.29 ^{c,d}	-1.35 ^{c,d}	2.12 (48.9) ^c
Cr(bpy) ₃ ³⁺	>1.6 ^{c,e}	-0.26 ^{c,d}	1.71 (39.4) ^c
Cr(CN) ₆ ³⁻	>1.6 ^f	-1.52 ^g	1.54 (35.5) ^g
Fe(CN) ₆ ⁴⁻	0.12 ^g	<-1.9 ^g	2.94 (67.8) ^g
Fe(CN) ₆ ³⁻	>0.52 ^g	0.12 ^g	2.91 (67.2) ^g
Ru(NH ₃) ₆ ³⁺		0.10 ⁱ	
metal ions			
Ce(aq) ³⁺	1.20 ^h		3.55 (81.9) ^c
Eu(aq) ³⁺		-0.67 ⁱ	2.17 (50.0) ^j
Eu(aq) ²⁺	0.67 ^j		3.88 (89.5) ^j
Fe(aq) ³⁺		0.53 ^h	1.60 (36.9) ^c
Fe(aq) ²⁺	~0.5 ^h		1.30 (29.9) ^j
Mn(aq) ²⁺	1.27 ^h		2.34 (54.0) ^j
Ti(aq) ³⁺		-0.60 ^k	~1.9 (~44) ^k
Tl(aq) ³⁺		-0.59 ^h	>4.5 (>103) ^l
UO ₂ ²⁺		0.06 ^m	2.54 (58.6) ^m

^a Redox potentials are reported vs. SCE in aqueous solution, unless otherwise noted (literature values vs. NHE are corrected). ^b Values in parentheses are reported in kcal/mol. ^c From ref 18 and references therein. ^d In CH₃CN. ^e In DMF vs. NHE. ^f Bolletta, F.; Maestri, M.; Balzani, V. *J. Phys. Chem.* 1976, 80, 2499; in DMF. ^g From ref 167 and references therein. ^h From ref. 103. ⁱ From ref 173. ^j From ref 203. ^k From ref. 181. ^l Estimated from onset of longest wavelength absorption. ^m From ref 201.

At room temperature spin-orbit coupling induced by the metal introduces a certain degree of singlet and triplet character into the excited state, but a precise description of the spin nature of the state is not yet available.

It is not surprising to see why this complex has attracted so much attention. Its excited state is produced efficiently ($\phi_{es} \sim 1$) after excitation; the lifetime of the excited state is $\sim 0.6 \mu s$; it emits strongly, allowing for convenient study by conventional Stern-Volmer techniques; and its Stokes shift is negligible.¹⁵⁶ Importantly, Ru(bpy)₃²⁺ has a low oxidation potential and high reduction potential.

Electron transfer and energy transfer have been confirmed for this sensitizer. With few exceptions, these reactions are rapid and normally are influenced only by the solvent shell reorganization (outer-sphere mechanism), since bond length changes during electron transfer are negligible (Table IV). Slow reactions can sometimes be traced to bond reorganizational changes in the quencher molecules or nonadiabatic effects because of poor orbital overlap.

The examples to be discussed here are shown in Table XIII. As indicated by the free energies calculated

TABLE XIII. Thermodynamic and Kinetic Parameters^a of Reactions Sensitized by Ru(bpy)₃²⁺

reaction	ΔG , kcal/mol ^b	k_q , M ⁻¹ s ⁻¹	ref
Ru(bpy) ₃ ²⁺ * + NB → Ru(bpy) ₃ ³⁺ + NB ⁻	7.47	2 × 10 ⁵	106
Ru(bpy) ₃ ²⁺ * + NB → Ru(bpy) ₃ ²⁺ + ³ NB*	11.1		
Ru(bpy) ₃ ²⁺ * + p-DNB → Ru(bpy) ₃ ³⁺ + p-DNB*	-3.9	8.6 × 10 ⁹	106
Ru(bpy) ₃ ²⁺ * + MV ²⁺ → Ru(bpy) ₃ ³⁺ + MV ⁺	-8.8	2.4 × 10 ⁹	106
Ru(bpy) ₃ ²⁺ * + MV ²⁺ → Ru(bpy) ₃ ²⁺ + ³ MV ²⁺	22.6		
Ru(bpy) ₃ ²⁺ * + DMA → Ru(bpy) ₃ ³⁺ + DMA ⁻	~1	7.4 × 10 ⁷	105
Ru(bpy) ₃ ²⁺ * + DMA → Ru(bpy) ₃ ²⁺ + ³ DMA*	19.1		
Ru(bpy) ₃ ²⁺ * + NTMP → Ru(bpy) ₃ ³⁺ + NTMP ⁺	-14.1	1.2 × 10 ¹⁰	105
Ru(bpy) ₃ ²⁺ * + NTMP → Ru(bpy) ₃ ²⁺ + ³ NTMP*	12.0		
Ru(bpy) ₃ ²⁺ * + Ru(NH ₃) ₆ ³⁺ → Ru(bpy) ₃ ³⁺ + Ru(NH ₃) ₆ ²⁺	-21.4	3.1 × 10 ⁹	186
Ru(bpy) ₃ ²⁺ * + Cr(CN) ₆ ³⁻ → Ru(bpy) ₃ ³⁺ + Cr(CN) ₆ ²⁻	>19.0		
Ru(bpy) ₃ ²⁺ * + Cr(CN) ₆ ³⁻ → Ru(bpy) ₃ ²⁺ + Cr(CN) ₆ ³⁻ *	-13.4	9.5 × 10 ⁸	168
Ru(bpy) ₃ ²⁺ * + Fe(Cen) ₆ ³⁻ → Ru(bpy) ₃ ³⁺ + Fe(CN) ₆ ⁴⁻	-21.9	6.5 × 10 ⁹	168
Ru(bpy) ₃ ²⁺ * + Fe(CN) ₆ ³⁻ → Ru(bpy) ₃ ²⁺ + Fe(CN) ₆ ³⁻ *	18.2		
Ru(bpy) ₃ ²⁺ * + Fe(CN) ₆ ⁴⁻ → Ru(bpy) ₃ ³⁺ + Fe(CN) ₆ ³⁻	-15.0	3.3 × 10 ⁹	168
Ru(bpy) ₃ ²⁺ * + Fe(CN) ₆ ⁴⁻ → Ru(bpy) ₃ ²⁺ + ³ Fe(CN) ₆ ⁴⁻ *	18.9		
Ru(bpy) ₃ ²⁺ * + Eu(aq) ³⁺ → Ru(bpy) ₃ ³⁺ + Eu(aq) ²⁺	-3.7	1.3 × 10 ⁵	173
Ru(bpy) ₃ ²⁺ * + Eu(aq) ³⁺ → Ru(bpy) ₃ ²⁺ + ³ Eu(aq) ³⁺ *	1.2		
Ru(bpy) ₃ ²⁺ * + Eu(aq) ²⁺ → Ru(bpy) ₃ ³⁺ + Eu(aq) ³⁺	-2.3	2.8 × 10 ⁷	173
Ru(bpy) ₃ ²⁺ * + Eu(aq) ²⁺ → Ru(bpy) ₃ ²⁺ + ³ Eu(aq) ²⁺	40.6		
Ru(bpy) ₃ ²⁺ * + Ti(aq) ³⁺ → Ru(bpy) ₃ ³⁺ + Ti(aq) ²⁺	-5.3		
Ru(bpy) ₃ ²⁺ * + Ti(aq) ³⁺ → Ru(bpy) ₃ ²⁺ + Ti(aq) ³⁺ *	-5.1	6.0 × 10 ⁶	181
Ru(bpy) ₃ ²⁺ * + Ti(aq) ³⁺ → Ru(bpy) ₃ ³⁺ + Ti(aq) ²⁺	-6.2	1.1 × 10 ⁸	175
Ru(bpy) ₃ ²⁺ * + Ti(aq) ³⁺ → Ru(bpy) ₃ ²⁺ + Ti(aq) ³⁺ *	>54.9		
Ru(bpy) ₃ ²⁺ * + UO ₂ ²⁺ → Ru(bpy) ₃ ³⁺ + UO ₂ ⁺	-20.5	4.4 × 10 ⁸	177
Ru(bpy) ₃ ²⁺ * + UO ₂ ²⁺ → Ru(bpy) ₃ ²⁺ + UO ₂ ²⁺ *	+9.7		
Ru(bpy) ₃ ²⁺ * + Fe ³⁺ (aq) → Ru(bpy) ₃ ³⁺ + Fe ²⁺ (aq)	-31.4	1.9 × 10 ⁹	175
Ru(bpy) ₃ ²⁺ * + Fe ³⁺ (aq) → Ru(bpy) ₃ ²⁺ + Fe ³⁺ (aq)	-12.0		

^a In CH₃CN or aqueous solvents. ^b ΔG for electron transfer calculated from eq 17.

by eq 17, electron transfer must play an important role in the majority of these reactions. Additional evidence is obtained by the methods discussed in section III. For example, plots of $\log k_q$ vs. the reduction potentials of a series of nitrobenzenes for the quenching of Ru(bpy)₃²⁺ follow the general lines expected of electron transfer.¹⁶² Energy transfer is thermodynamically ruled out. Microsecond flash photolysis experiments have failed to detect free ion transient intermediates having lifetimes greater than 50 μ s. It appears likely that rapid reversible electron transfer can consume the ion pair before escape from the cage into the bulk solvent where spectroscopic detection of long-lived intermediates is possible. Given that electron transfer would generate ions of opposite charge which remain in close proximity because of Coulombic attraction, this argument appears reasonable.

Ru(bpy)₃²⁺* can also donate an electron to substituted pyridinium ions such as methylviologen.¹⁶³ Energetics and plots of $\log k_q$ vs. the reduction potentials of the pyridinium compounds are consistent with electron transfer.^{105,164} Unlike the quenching reactions involving the nitrobenzene quenchers, transient radical ions produced by flash photolysis are easily observable.¹⁶³ Both of the ion radicals have a positive charge and therefore have a tendency to separate. A resonance Raman spectrum of the methylviologen cation has also been obtained using a focused laser beam.¹¹⁶ The lifetime of the MV⁺ can be increased when the reaction is carried out in the presence of amines to allow for detection by ESR:¹⁶⁵

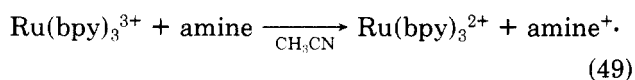

amine = pyridine; 2,6-lutidine;

N,N-dimethylformamide; triethylamine

Energetics and flash photolysis experiments support an electron-transfer pathway when Ru(NH₃)₆³⁺^{163,165} and Fe(CN)₆³⁻¹⁶⁷⁻¹⁶⁹ are employed as quenchers. Reversible electron transfer returns the transient ion pair to ground-state reactants before chemical changes occur. Evidence for electron transfer, in the case of Ru(NH₃)₆³⁺, has been provided by flash photolysis.¹⁶³ Cr(CN)₆³⁻, a complex with a low-lying excited state (Table XII), quenches by energy transfer. Its luminescence is observed when Ru(bpy)₃²⁺ solutions are photolyzed in the presence of Cr(CN)₆³⁻. A consideration of the data in Tables X and XII leads to the conclusion that energy transfer is the exclusive quenching pathway.^{167,168,170,171}

Ru(bpy)₃²⁺* has been reported to reduce Eu³⁺,¹⁷²⁻¹⁷⁴ Tl³⁺,^{175,176} and UO₂²⁺.¹⁷⁷ Thermodynamic, kinetic, and flash spectroscopy support electron transfer. It is noteworthy that the rate constants for the Ru(bpy)₃²⁺-Eu³⁺ couple (Table XIII) are much lower than diffusion-controlled rates. This observation has been taken to indicate a nonadiabatic mechanism, one that is controlled by electronic rather than by nuclear factors.¹⁷⁸ This interpretation is based upon the fact that the accepting 4f orbital of Eu³⁺ is heavily shielded by outer 5s and 5d orbitals, thereby preventing orbital overlap, which is a prerequisite for an adiabatic mechanism. Calculations indicate minimal nuclear changes.

Quenching by Ti³⁺ probably proceeds by both energy transfer.^{179,180} Thermodynamics (Table XIII) supports this conclusion, as well as several investigations.¹⁷⁹⁻¹⁸¹

The Ru(bpy)₃²⁺*-Fe³⁺ couple illustrates the hazards in relying exclusively on flash photolysis techniques.^{18,174} High yields of transient Ru(bpy)₃³⁺ and Fe²⁺ in an aqueous medium have been confirmed by flash spectroscopic studies.^{163,174} Taken by itself, this observation

would appear to be consistent with electron transfer, were it not for the presence of unusually low-lying excited states of Fe^{3+} (Table XII), which can be populated by collisional energy transfer. Following energy transfer to populate Fe^{3+} , the latter can accept an electron from $\text{Ru}(\text{bpy})_3^{2+}$ in an exothermic reaction ($\Delta G = -20.1$ kcal/mol):

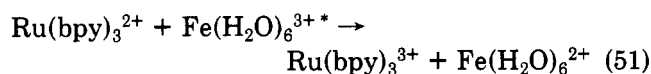
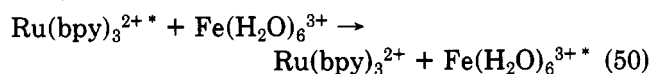

An elaborate kinetic argument has been proposed, however, to support primary electron transfer.¹⁷⁴

The preceding examples have described the oxidation of $\text{Ru}(\text{bpy})_3^{2+}$. The ability of certain substrates to reduce $\text{Ru}(\text{bpy})_3^{2+}$ by electron donation has also been documented. Amines are typical electron donors. Their high-lying excited states preclude competitive energy transfer (Table XI). Flash spectroscopy has been useful in identifying the amine cation radical produced by an electron-transfer pathway.¹⁸²⁻¹⁸⁵ For example, the cations of *N,N*-dimethylaniline and tetramethyl-*p*-phenylenediamine have been detected following flash photolysis of solutions containing their parent amines and $\text{Ru}(\text{bpy})_3^{2+}$.¹⁸² The rate of cation disappearance has been measured and correlated with the rate of return to ground-state reactants, since no permanent spectral changes are observed following repetitive flashings. $\log k_q$ vs. the oxidation potentials of a series of amines plots follow the general trends predicted for electron transfer.¹⁰⁶

Reduction of $\text{Ru}(\text{bpy})_3^{2+}$ can take place in the presence of metal complexes. For example, thermodynamic arguments have been advanced to assign electron transfer to the quenching by $\text{Fe}(\text{CN})_6^{4-}$ complexes.¹⁶⁷⁻¹⁶⁹ In the case of reductive quenching by Eu^{2+} , however, a conclusion that the mechanism involves electron transfer must be regarded as only tentative, since the excited-state energies of Eu^{2+} have not been positively determined.¹⁷³ Detailed kinetic arguments seem to suggest that quenching involves electron transfer.¹⁸⁶

The isomerization of olefins can be a diagnostic tool for distinguishing between energy and electron transfer. It is possible to differentiate between these pathways by a comparison of the photostationary products obtained from an unknown pathway with the products obtained utilizing a "standard" sensitizer, which is known to proceed by energy transfer. For example, benzophenone, a triplet sensitizer, is known to be quenched by *cis*- and *trans*-olefins with low-lying excited states and gives photostationary mixtures consisting largely of the *cis* isomer. If electron transfer is operating for a given sensitizer, we predict that the radical-type intermediates resulting from electron transfer should give radical-type which favor forming of more stable *trans* isomers. Thus, the quenching of $\text{Ru}(\text{bpy})_3^{2+}$ by *trans*-stilbene, *trans*-4-styrylpyridine, and *trans*-2-styrylpyridine (all of which have triplet energies near 50 kcal/mol) has been postulated to proceed largely by energy transfer, as *cis* isomers are the predominant products.¹⁸⁷

On the other hand, the $\text{Ru}(\text{bpy})_3^{2+}$ -sensitized isom-

erization of *N*-methyl-4- β -styrylpyridinium favors *cis* to *trans* conversion:¹⁸⁸

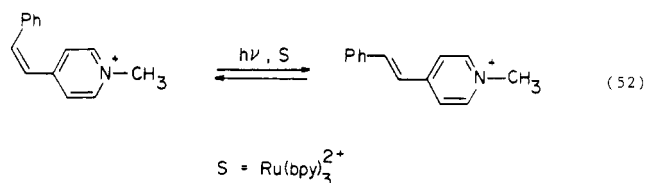

Although the triplet-state energy of the pyridinium compounds is about 50 kcal/mol, energy transfer favoring the *cis* isomer cannot be the major pathway. Isomerization most likely proceeds by electron transfer:

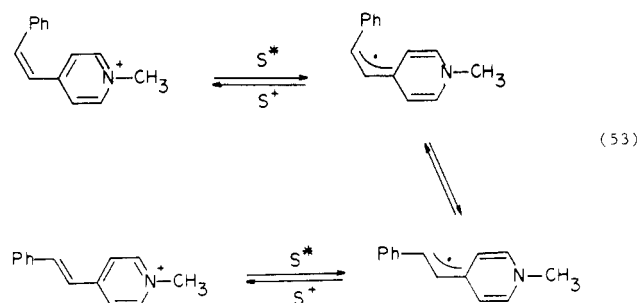

Quenching of $\text{Ru}(\text{bpy})_3^{2+}$ by a series of *cis*- and *trans*-dipyridylethylenes has been shown to proceed by both pathways (Table XIV).¹⁸⁹ Energy transfer to the triplet states of these olefins ($E_T \sim 50$ kcal/mol) and electron-transfer oxidation of the sensitizer are energetically feasible. Although these olefins quench $\text{Ru}(\text{bpy})_3^{2+}$ near diffusion-controlled rates, the efficiency of isomerization, especially for 1-(3-pyridyl)-2-(4-pyridyl)ethylene and 1,2-di-(4-pyridylethylene, drops significantly. Electron transfer must play a role, as deduced from the detection of transient intermediates produced by flash photolysis. However, an analysis of $\log k_q$ vs. redox potential plots seems to suggest competing energy and electron-transfer pathways. It seems plausible that the direction of the quenching process in *cis* *trans* isomerization depends on nuclear (kinetic) barriers.

b. Chromium(II) Tris(bipyridyl) Complexes. $\text{Cr}(\text{bpy})_3^{3+}$ can form transient ions efficiently following quenching by a variety of inorganic and organic substrates.¹⁵⁵ The lowest excited state consists of two closely spaced emitting states in thermal equilibrium. They apparently have doublet character, and it is customary to apply the 2E level to these states.¹⁵⁵ As expected from its long lifetime and high reduction potential (Table X), $\text{Cr}(\text{bpy})_3^{3+}$ should be easily reduced by electron donors. This prediction is supported on several bases (Table XV). Plots of $\log K_q$ vs. oxidation potentials of electron donors such as aliphatic amines, aromatic amines, and methoxybenzenes show the dependence expected for electron transfer.¹⁹⁰ Transient cations of these quenchers have also been observed by flash photolysis.¹⁹⁰

$\text{Cr}(\text{bpy})_3^{3+}$ can be quenched by $\text{Ru}(\text{bpy})_3^{2+}$ to generate ionic products. Energy transfer is forbidden thermodynamically. One study has shown that if a series of polypyridine chromium complexes with differing substituents on the ligands are systematically quenched by $\text{Ru}(\text{bpy})_3^{2+}$, k_q is dependent upon the reduction potential of the sensitizer, clearly establishing the charge-transfer nature of the quenching.⁷⁹

TABLE XIV. Isomerization of *cis*- and *trans*-Dipyridylethylenes Sensitized by Ru(bpy)₃²⁺^a

quencher	$\Phi_{t \rightarrow c}$	k_q	k_{et}^b	k_{ET}^c
1,2-di-3-pyridylethylene	0.45	6.8×10^6	7×10^5	6.1×10^6
1-(3-pyridyl)-2-(4-pyridyl)ethylene	0.02	9.1×10^8	8.7×10^8	3.6×10^7
1,2-di-(4-pyridylethylene)	0.007	2.4×10^9	2.4×10^9	3.4×10^7

^a From ref 189. ^b Rate of electron transfer. ^c Rate of energy transfer.TABLE XV. Thermodynamic and Kinetic Parameters of Reactions Sensitized by Cr(bpy)₃³⁺^a

reaction	ΔG , kcal/mol ^b	k_q , M ⁻¹ s ⁻¹	ref
Cr(bpy) ₃ ³⁺ + TPA → Cr(bpy) ₃ ²⁺ + TPA ⁺	-10.8	7.3×10^9	190
Cr(bpy) ₃ ³⁺ + TPA → Cr(bpy) ₃ ³⁺ + ³ TPA*	30.7		
Cr(bpy) ₃ ³⁺ + NTMB → Cr(bpy) ₃ ²⁺ + NTMB ⁺	-26.1	1.1×10^{10}	190
Cr(bpy) ₃ ³⁺ + NTMB → Cr(bpy) ₃ ³⁺ + ³ NTMB*	23.5		
Cr(bpy) ₃ ³⁺ + Ru(bpy) ₃ ²⁺ → Cr(bpy) ₃ ²⁺ + Ru(bpy) ₃ ³⁺	-4.4	4.0×10^8	c
Cr(bpy) ₃ ³⁺ + Ru(bpy) ₃ ²⁺ → Cr(bpy) ₃ ³⁺ + Ru(bpy) ₃ ²⁺ *	9.5		
Cr(bpy) ₃ ³⁺ + Fe(CN) ₆ ⁴⁻ → Cr(bpy) ₃ ²⁺ + Fe(CN) ₆ ³⁻	-30.7	4.9×10^9	168
Cr(bpy) ₃ ³⁺ + Fe(CN) ₆ ⁴⁻ → Cr(bpy) ₃ ³⁺ + Fe(CN) ₆ ⁴⁻ *	28.4		
Cr(bpy) ₃ ³⁺ + Cr(CN) ₆ ³⁻ → Cr(bpy) ₃ ²⁺ + Cr(CN) ₆ ²⁻	>3.5		
Cr(bpy) ₃ ³⁺ + Cr(CN) ₆ ³⁻ → Cr(bpy) ₃ ³⁺ + Cr(CN) ₆ ³⁻ *	-3.9	4.1×10^9	168
Cr(bpy) ₃ ³⁺ + Fe(aq) ²⁺ → Cr(bpy) ₃ ²⁺ + Fe(aq) ³⁺	-22	4.1×10^7	170
Cr(bpy) ₃ ³⁺ + Fe(aq) ³⁺ → Cr(bpy) ₃ ³⁺ + Fe(aq) ³⁺ *	-9.5		

^a In CH₃CN or aqueous solvents. ^b ΔG for electron-transfer calculated from eq 17. ^c Bolletta, F.; Maestri, M.; Moggi, L.; Balzani, V. *J. Chem. Soc., Chem. Commun.* 1975, 901.TABLE XVI. Thermodynamic and Kinetic Parameters of Reactions Sensitized by Binuclear Complexes^a

reaction	ΔG , kcal/mol ^b	k_q , M ⁻¹ s ⁻¹	reference
Rh ₂ (dicp) ₄ ²⁺ + MV ²⁺ → Rh ₂ (dicp) ₄ ³⁺ + MV ⁺	<-8.1	1.1×10^9	194
Rh ₂ (dicp) ₄ ²⁺ + MV ²⁺ → Rh ₂ (dicp) ₄ ²⁺ + ³ MV ²⁺	32.5		
Rh ₂ (dicp) ₄ ²⁺ + DMA → Rh ₂ (dicp) ₄ ⁺ + DMA ⁺	12	< 1×10^5	194
Rh ₂ (dicp) ₄ ²⁺ + DMA → Rh ₂ (dicp) ₄ ²⁺ + ³ DMA*	30		
Rh ₂ (dicp) ₄ ²⁺ + NTMB → Rh ₂ (dicp) ₄ ⁺ + NTMB ⁺	-2.1	8.7×10^8	194
Rh ₂ (dicp) ₄ ²⁺ + NTMB → Rh ₂ (dicp) ₄ ²⁺ + NTMB*	21.9		
Rh ₂ (dicp) ₄ ²⁺ + anthracene → Rh ₂ (dicp) ₄ ⁺ + anthracene	20.1		
Rh ₂ (dicp) ₄ ²⁺ + anthracene → Rh ₂ (dicp) ₄ ³⁺ + anthracene ⁻	26.1		
Rh ₂ (dicp) ₄ ²⁺ + anthracene → Rh ₂ (dicp) ₄ ²⁺ + ³ anthracene*	3.7	3.4×10^6	194
Rh ₂ (dicp) ₄ ²⁺ + <i>trans</i> -stilbene → Rh ₂ (dicp) ₄ ³⁺ + <i>trans</i> -stilbene ⁻	33.7		
Rh ₂ (dicp) ₄ ²⁺ + <i>trans</i> -stilbene → Rh ₂ (dicp) ₄ ²⁺ + ³ <i>trans</i> -stilbene*	9.9	$\leq 4.0 \times 10^5$	194
Re ₂ Cl ₈ ²⁻ + DMA → Re ₂ Cl ₈ ³⁻ + DMA ⁺	-2.1	1.5×10^6	
Re ₂ Cl ₈ ²⁻ + DMA → Re ₂ Cl ₈ ³⁻ + ³ DMA*	28.6		
Re ₂ Cl ₈ ²⁻ + NTMB → Re ₂ Cl ₈ ³⁻ + NTMB ⁺	-18.4	5.4×10^9	197
Re ₂ Cl ₈ ²⁻ + NTMB → Re ₂ Cl ₈ ³⁻ + ³ NTMB*	20.5		
Pt ₂ (P ₂ O ₅) ₄ H ₈ ⁴⁻ + BSEP ^c → Pt ₂ (P ₂ O ₅) ₄ H ₈ ³⁻ + BSEP ⁻		5.5×10^9	198
Pt ₂ (P ₂ O ₅) ₄ H ₈ ⁴⁻ + NTMB → Pt ₂ (P ₂ O ₅) ₄ H ₈ ⁵⁻ + NTMB ⁺	-18.0	1.2×10^{10}	200
Pt ₂ (P ₂ O ₅) ₄ H ₈ ⁴⁻ + NTMB → Pt ₂ (P ₂ O ₅) ₄ H ₈ ⁴⁻ + ³ NTMB*	-5.3		

^a In CH₃CN or aqueous solvents. ^b ΔG for electron transfer calculated from eq 17. ^c BSEP = 1,1'-bis(2-sulfoethyl)-4,4'-bipyridinium.

Energy-transfer pathways have been reported for Cr(bpy)₃³⁺. For example, Cr(CN)₆³⁻, which has low-lying excited states, quenches this sensitizer by energy transfer.¹⁶⁸ Evidence for this conclusion has been provided by the emission of Cr(CN)₆³⁻ has been directly observed. Quenching by cyano complexes with higher excited-state energies such as Fe(CN)₆⁴⁻ is probably by electron transfer, since the quenching rate constant is sensitive to the oxidation potential of the cyano quencher.¹⁶⁸ A recent study employing laser photolysis has verified the presence of Cr(bpy)₃²⁺ when Fe(aq)²⁺ compounds were employed as quenchers.¹⁹¹ In this example, energy transfer may be a competing pathway (Table XIV).

c. Binuclear Complexes. An intriguing class of sensitizers includes the binuclear transition-metal complexes (Table X). Tetrakis(1,3-diisocyanopropane)dichromium, Rh₂(dicp)₄²⁺, can be excited at about 550 nm to generate two emissive states which have been assigned as ¹A_{2u} and ³A_{2u} excited states.^{192,193} Excited-state formation involves promotion of an electron from a 4d to a 5p orbital. Molecular orbital theory predicts

the Rh-Rh bond is shorter in the excited state than in the ground state.¹⁹² Polarized absorption studies have confirmed this prediction.¹⁹³

The long-lived triplet state of Rh₂(dicp)₄²⁺ is predicted to be reactive in electron transfer, based upon its redox potential (Table XVI). Flash photolysis has, for example, demonstrated the presence of a transient spectrum of Rh₂(dicp)₄³⁺ when pyridinium compounds are employed as ground-state electron acceptors.¹⁹⁴ Rh₂(dicp)₄³⁺ can be quenched by electron donation from Rh₂(dicp)₄³⁺ can be quenched by electron donation from tetramethylphenylene-*p*-diamine, as suggested by flash photolysis experiments.¹⁹⁴ Dimethylaniline and DABCO also quench the emission of this sensitizer but at lower rates, presumably because of the reduced driving force of these reactions.

The excited state of Re₂Cl₈²⁻ is also capable of accepting and donating electrons.^{195,196} Flash spectroscopic studies have demonstrated the presence of transient intermediates when electron acceptors such as chloranil or tetracyanoethylene are used as quenchers.¹⁹⁷ Although no transient amine cations were de-

TABLE XVII. Thermodynamic and Kinetic Parameters of Reactions Sensitized by UO_2^{2+} ^a

reaction	ΔG , kcal/mol ^b	k_q , $\text{M}^{-1} \text{s}^{-1}$	ref
$\text{UO}_2^{2+*} + \text{DMA} \rightarrow \text{UO}_2^+ + \text{DMA}^{\cdot}$	-41.3	$\sim 10^{10}$	209
$\text{UO}_2^{2+*} + \text{DMA} \rightarrow \text{UO}_2^{2+} + {}^3\text{DMA}^*$	10.4		
$\text{UO}_2^{2+*} + \text{Ru}(\text{bpy})_3^{2+} \rightarrow \text{UO}_2^+ + \text{Ru}(\text{bpy})_3^{3+}$	-30.9	3.7×10^9	177
$\text{UO}_2^{2+*} + \text{Ru}(\text{bpy})_3^{2+} \rightarrow \text{UO}_2^{2+} + \text{Ru}(\text{bpy})_3^{2+*}$	-9.7		
$\text{UO}_2^{2+*} + \text{Ce}(\text{aq})^{3+} \rightarrow \text{UO}_2^+ + \text{Ce}(\text{aq})^{4+}$	-32.3	2×10^5	206
$\text{UO}_2^{2+*} + \text{Ce}(\text{aq})^{3+} \rightarrow \text{UO}_2^{2+} + \text{Ce}(\text{aq})^{3+*}$	23.3		
$\text{UO}_2^{2+*} + \text{Fe}(\text{aq})^{2+} \rightarrow \text{UO}_2^+ + \text{Fe}(\text{aq})^{3+}$	-48	6.7×10^8	204
$\text{UO}_2^{2+*} + \text{Fe}(\text{aq})^{2+} \rightarrow \text{UO}_2^{2+} + \text{Fe}(\text{aq})^{2+*}$	-27.7		
$\text{UO}_2^{2+*} + \text{Mn}(\text{aq})^{2+} \rightarrow \text{UO}_2^+ + \text{Mn}(\text{aq})^{3+}$	-30.7	3.4×10^6	204
$\text{UO}_2^{2+*} + \text{Mn}(\text{aq})^{2+} \rightarrow \text{UO}_2^{2+} + \text{Mn}(\text{aq})^{2+*}$	-4.6		
$\text{UO}_2^{2+*} + \text{Eu}(\text{aq})^{3+} \rightarrow \text{UO}_2^{2+} + \text{Eu}(\text{aq})^{3+*}$	-8.5		203

^a In CH_3CN or aqueous solvents. ^b ΔG for electron transfer calculated from eq 17.

tected with secondary and tertiary amines, plots of $\log k_q$ vs. the oxidation potentials of amines strongly suggest electron transfer. The lack of observable transient ions was attributed to rapid reversible electron transfer.

Another bridged binuclear species capable of electron transfer is the excited state of $\text{Pt}_2(\text{P}_2\text{O}_5)_4\text{H}_8^{4-}$.¹⁹⁸ Emitting singlet and triplet states with electronic configurations similar to the states of $\text{Rh}_2(\text{dicp})_4^{2+}$ have been postulated. Resonance Raman spectral studies have established that the Pt-Pt bonding in the ${}^3\text{A}_{2u}$ excited state is shorter than in its ground state.¹⁹⁹ The phosphorescence of $\text{Pt}_2(\text{P}_2\text{O}_5)_4\text{H}_8^{4-}$ can be quenched by such acceptors as 1,1'-bis(2-sulfoethyl)-4,4'-bipyridinium (BSEP) at diffusion-controlled rates.¹⁹⁸ Flash photolysis has revealed a transient absorption of BSEP⁻, which disappears rapidly by reversible electron transfer. Amines have also been reported to quench the triplet state of $\text{Pt}_2(\text{P}_2\text{O}_5)_4\text{H}_8^{4-}$. The rate of quenching of $\text{Pt}_2(\text{P}_2\text{O}_5)_4\text{H}_8^{4-}$ is much lower than for the quenching of other sensitizers such as $\text{Ru}(\text{bpy})_3^{2+}$. These differences have been ascribed to bond reorganization barriers accompanying the reduction of $\text{Pt}_2(\text{P}_2\text{O}_5)_4\text{H}_8^{4-}$.²⁰⁰

d. Uranyl Ion Complexes. The most powerful photooxidant of the metal complexes listed in Table X is UO_2^{2+} , and extensively investigated photosensitizer.^{18,201} The ground-state electronic configuration involves overlap between the oxygen 2p and uranium 6d orbitals. Low-energy excitation of UO_2^{2+} complexes can result in promotion of one of the electrons in a highest filled bonding π -orbital into a vacant metal-centered 5f orbital, where the electron assumes nonbonding character.^{201,202}

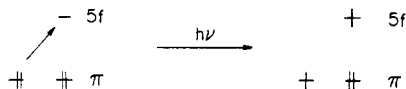

The lowest excited state is relatively long-lived and displays a characteristically intense green luminescence at room temperature. As with other heavy metal complexes, the spin nature of this state is ill-defined, since extensive spin-orbital coupling is involved.¹⁸

On the basis of an unusually high reduction potential, UO_2^{2+} is predicted to be a powerful electron acceptor (Table XVII). For example, the quenching of UO_2^{2+} luminescence by many metal ions correlates closely with the ionization potentials of these ions.^{203,204} The mechanism of electron transfer is thought to involve a transfer of an electron from the metal to the vacant π -orbital of UO_2^{2+} . In the case of Mn^{2+} , flash photolysis experiments have given evidence of a transient absorption pattern consistent with Mn^{3+} .²⁰⁴ An electron

transfer has been suggested in which Mn^{3+} is formed by electron transfer.^{204,205}

Laser flash experiments have revealed transient absorption of Ce^{4+} when Ce^{3+} is employed as a quencher.²⁰⁶ Energy transfer for this system is too endothermic to be of any importance. Metal ions with low-lying electronic states, however, have been shown to quench efficiently by energy transfer. For example, the sensitized emission of Eu^{3+} has been observed.²⁰³

Electron transfer is a possible quenching pathway when transition-metal complexes are employed. Thus, upon flash photolysis, UO_2^{2+} is quenched by $\text{Ru}(\text{bpy})_3^{2+}$ leading to $\text{Ru}(\text{bpy})_3^{3+}$.¹⁷⁷ Although populating $\text{Ru}(\text{bpy})_3^{2+*}$ by energy transfer cannot be rigorously ruled out, kinetic studies demonstrate that the rate of appearance of $\text{Ru}(\text{bpy})_3^{3+}$ closely parallels the rate of disappearance of $\text{Ru}(\text{bpy})_3^{2+}$. Excitation of either $\text{Ru}(\text{bpy})_3^{2+}$ or UO_2^{2+} gives the identical intermediates. The combination of these sensitizers can therefore "capture" a larger portion of the wavelengths in the visible region.

The quenching of UO_2^{2+} by transition-metal cyano complexes proceeds by either electron or energy transfer, and, in some cases, by competitive pathways.^{203,207,208}

UO_2^{2+} is an effective oxidant of many organic substrates. Flash photolysis experiments have provided evidence of transient UO_2^+ when UO_2^{2+} is excited in the presence of alcohols, phenols, quinones, or amines.²⁰⁹ Isotopic and ESR studies have suggested that the quenching of UO_2^{2+} by organic alcohols may also proceed by abstraction of hydrogen atoms substituted on the carbon atom adjacent to the functional group:^{18,210-212}



In the presence of aromatic hydrocarbons, electron transfer has been postulated to proceed via nonluminescent exciplex intermediates, based upon the favorable overlap which is possible between the MO's of molecules with accessible π -electron systems and half-vacant π -orbital of UO_2^{2+} .²¹³

e. Metalloporphyrins. The metalloporphyrins have received considerable attention because of their special role in photosynthesis. Many metalloporphyrins are brilliantly colored substances and can be excited in the visible into the first excited singlet state, followed by fluorescence emission or intersystem crossing to triplet states. Triplet-state production is generally an efficient process for metalloporphyrins, as compared to the metal-free parent compounds, because of the increased spin-orbital coupling induced by the central metal

TABLE XVIII. Thermodynamic and Kinetic Parameters of Reactions Sensitized by Metalloporphyrins^a

reaction	ΔG , kcal/mol ^b	k_q , M ⁻¹ s ⁻¹	ref
¹ ZnTPPyP ⁴⁺ * + MV ²⁺ → ZnTPPyP ⁵⁺ + MV ⁺	-15.2	<3 × 10 ⁷	214
³ ZnTPPyP ⁴⁺ * + MV ²⁺ → ZnTPPyP ⁵⁺ + MV ⁺	-4.2	1.8 × 10 ⁷	214
³ ZnTPPyP ⁴⁺ * + MV ²⁺ → ZnTPPyP ⁴⁺ + ³ MV ²⁺ *	35.3		
³ ZnTPP* + O ₂ → ZnTPP ⁺ + O ₂ ⁻	-2.3		237
³ ZnTPP* + O ₂ → ZnTPP + O ₂ (¹ Δ)	-14.1		237

^a In CH₃CN or aqueous solvents. ^b ΔG for electron transfer calculated from eq 17.

atom. Both the lowest singlet and triplet states have a π, π^* electron configuration. These states are generally good electron donors. The electron-transfer process probably involves abstraction of one of the electrons delocalized over the entire excited porphyrin ring. The photophysical and redox properties of zinc tetraphenylporphyrin, a prototype porphyrin, are summarized in Table X.

Many examples of the bimolecular quenching of metalloporphyrins have involved their oxidation by electron transfer (Table XVIII). It has in fact been demonstrated that quenching of the excited singlet and triplet metalloporphyrins can easily be achieved with electron acceptors.²¹⁴⁻²¹⁸ The fluorescence of these sensitizers can be quenched at diffusion-controlled rates by ground-state molecules with electron-withdrawing properties. The quenching rate constants are sensitive to the reduction potentials of the quencher.²¹⁸⁻²²¹ Still, direct evidence for electron transfer has been difficult to obtain.²¹⁷ This difficulty is partly due to the rapid recombination predicted for singlet ion pairs formed from the quencher and excited porphyrin (porphyrins are planar molecules and probably remain in fairly close contact as exciplexes or contact ion pairs).²²² Ground-state complexation can also alter the efficiency of excited-state formation.²²³⁻²²⁵ This troublesome feature can be reflected in departure from linearity in Stern-Volmer plots.²²⁶

Only a few attempts to detect ionic species following fluorescence quenching have been made.^{227,228} For example, the observation of ion pairs is expected to be enhanced by substitution of appropriately charged groups on the porphyrin ring.²¹⁴ On this basis, the oxidation of a pyridinium-substituted zinc porphyrin groups by methylviologen should result in two positively charged ions following fluorescence quenching. This prediction, however, is not fulfilled, apparently because of a large Coulombic barrier for electron transfer between two like-charged species.²¹⁷

Direct evidence for electron transfer has been easier to obtain in the quenching of triplet states.^{27,218-221,229-236} Experiments employing flash photolysis have been definitive in providing evidence of ionic species derived from the quenching of triplet porphyrins. Both the lifetimes of the triplet metalloporphyrins and the generated ion pairs permit fairly straightforward conclusions to be drawn.

Excited states of metalloporphyrins and porphyrins are quenched by oxygen via energy and electron-transfer pathways (Table XVIII).²³⁷ These reactions stand as elegant examples of the competition between energy and electron transfer under conditions where both pathways are exothermic. Singlet oxygen can be generated by oxygen quenching of triplet porphyrins

via energy transfer. The pathway may be concerted or involve stepwise electron exchange:

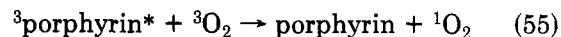

or

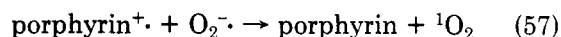
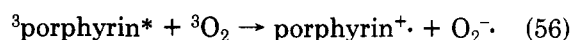

In the stepwise mechanism, superoxide, O₂⁻, is an ionic precursor of singlet oxygen. Under polar conditions, superoxide is sufficiently long-lived to be detected by ESR spin trapping techniques. The yield of superoxide is not affected by addition of DABCO, a singlet oxygen quencher, indicating that superoxide is formed directly during quenching, not from singlet oxygen. Both singlet oxygen and superoxide have been detected in the quenching of triplet octaethylporphyrin, although singlet oxygen formation predominates. Although singlet oxygen can be formed directly or via superoxide, increasing the solvent polarity does not affect its yield. It is concluded that direct formation is the predominant pathway for singlet oxygen formation.

Sensitized photooxygenations involving superoxide are covered in more detail in section IV.C.4.

f. Copper(I) Bis(2,9-diphenyl-1,10-phenanthroline). Competitive electron and energy transfer has been observed for Cu(dpp)₂⁺.²³⁸ The lone-lived, luminescent triplet state of this sensitizer can be quenched by a variety of Cr(III) derivatives and nitroaromatic compounds. The kinetics have been measured by Stern-Volmer procedures and analyzed by Marcus theory. Plots of log k_q vs. the reduction potentials of a series of nitrobenzenes have shown that quenching of Cu(dpp)₂⁺ occurs predominantly by electron transfer, since the expected rate plateau is observed in the very exothermic region. These results have permitted a measurement of the self-exchange rate constant for this sensitizer (eq 41 and Table VI) on the basis of an outer-sphere mechanism. Quenching by derivatives of Cr(III) give more complicated plots, and these results are interpreted in terms of competitive energy and electron transfer.

2. Quenching of the Excited States of Aromatic Hydrocarbons and Ketones by Amines

The quenching of excited-state aromatic and carbonyl

TABLE XIX. Thermodynamic and Kinetic Parameters of Electron-Transfer Reactions When Amines are Employed as Quenchers^a

reaction	ΔG , kcal/mol ^b	k_q , M ⁻¹ s ⁻¹	ref
¹ anthracene* + NDEA \rightarrow anthracene ⁻ + NDEA ⁺ .	-14.3	2.1×10^{10}	c
¹ anthracene* + NDEA \rightarrow anthracene + ¹ NDEA*	>13		
¹ trans-stilbene* + TEA \rightarrow trans-stilbene ⁻ + TEA ⁺ .	-11.8	3.2×10^{10}	261
¹ trans-stilbene + TEA \rightarrow trans-stilbene + ¹ TEA*	>8.5		
¹ trans-stilbene* + DABCO \rightarrow trans-stilbene ⁻ + DABCO ⁺ .	-16.1	11×10^{10}	261
¹ trans-stilbene* + DABCO \rightarrow trans-stilbene + ¹ DABCO*	>8.5		
¹ pyrene-3-carboxylic acid* + DMA \rightarrow pyrene-3-carboxylic acid ⁻ + DMA ⁺ .	-15.9	1.8×10^{10}	42
¹ pyrene-3-carboxylic acid* + DMA \rightarrow pyrene-3-carboxylic acid + ¹ DMA*	>15.7		
³ benzophenone* + DABCO \rightarrow benzophenone ⁻ + DABCO ⁺ .	-17.3	2.9×10^9	244
³ benzophenone* + DABCO \rightarrow benzophenone + ³ DABCO*	>20		

^aIn CH₃CN or aqueous solvents. ^b ΔG for electron transfer calculated from eq 17. ^cKnibbe, H.; Rehm, D.; Weller, A. *Ber. Bunsenges. Phys. Chem.* 1968, 72, 257.

molecules by amines can be described by the following pathway:²³⁹

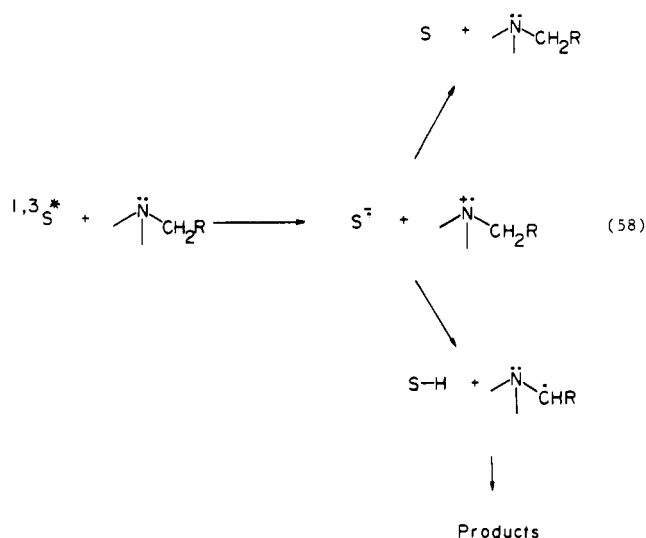

The following generalizations appear to hold for this reaction:

(1) The overall thermodynamics of the reaction unambiguously and exclusively favor electron transfer for many sensitizer-amine pairs (Table XIX).

(2) The rate constants are sensitive to the electronic energies and reduction potentials of the sensitizers and oxidation potentials of the amines, as well as the structures of both sensitizers and amines.²³⁹ In general, amines with low ionization potentials are the most effective electron donors.^{239,240} The trend reflects the stability of the amine cations.

(3) The reaction is sequential. After primary electron transfer, proton abstraction competes with back electron transfer.²³⁹

(4) Only amines with α -protons are capable of proton atom donation. Amines not possessing α -protons can quench excited states, but back electron transfer to ground-state reactants is the exclusive pathway after formation of ionic intermediates.^{239,240}

(5) The singlet states of aromatic hydrocarbons and the singlet and triplet states of carbonyl compounds can be quenched by amines by the proposed mechanism.²³⁹⁻²⁴¹ With carbonyl compounds, n, π^* and π, π^* states can be involved. The reactions may differ, based upon other factors, i.e., excited state, lifetimes, steric effects, symmetry, etc.²⁴⁰

(6) Solvent-separated ion pairs, contact ion pairs, exciplexes, and free ions have all been identified as charge-transfer intermediates with amines. "Relaxed" and "nonrelaxed" solvent-separated ion pairs have been postulated and investigated.⁴⁵ The exciplexes in these systems may be considered contact ion pairs and may or may not display emission. A clearcut distinction between exciplexes and other charge-transfer intermediates may not always be possible.⁴⁴ In general, in nonpolar solvents the quenching of excited aromatic molecules by amines may lead to fluorescent exciplexes.

Solvent, kinetic, time-resolved spectroscopic, and CIDNP studies have lent strong support to the concept of electron transfer in the primary step, regardless of the precise nature of the resulting ionic intermediates or subsequent secondary reactions. For example, it has been shown that perylene fluorescence is quenched by *N,N*-dimethylaniline in nonpolar solvents resulting in the appearance of a broad and structureless emission, displayed somewhat to the red of the perylene emission.⁵ In polar solvents, this structureless emission disappears. Instead radical ions are probably formed, as suggested by microsecond flash photolysis experiments.^{42,242,243}

With excited aromatic and carbonyl molecules sensitizers, $\log k_q$ vs. ionization potential plots are characteristic of electron transfer.^{42,239,242-245} In the case of n, π^* triplet benzophenone, the small slopes of k_q vs. ionization potential plots and lack of sensitivity to solvent polarity are consistent of a transition state with only "partial" electron transfer. A modification of the Weller equation (eq 16) has been proposed to take into account the thermodynamics of the proton transfer step.²⁴⁶

These observations contrast with quenching reactions sensitized by π, π^* triplet fluorenone. With aromatic and aliphatic amines, these reactions are more sensitive to solvent polarity and yield steeper slopes, suggesting a more "complete" transfer of charge in the transition state. The contrasting sensitivity of n, π^* and π, π^* states to solvent polarity may correlate with differences in the transition states.^{239,240,244}

Direct evidence of radical ion intermediates has been provided by time-resolved studies. Besides conventional microsecond flash photolysis,²⁴⁷⁻²⁴⁹ nanosecond and picosecond laser-induced spectroscopy has been invaluable in helping to identify the ionic intermediates.^{45,46,250-258}

The quenching of *trans*-stilbene in acetonitrile by trialkylamines and diamines has been reported to result

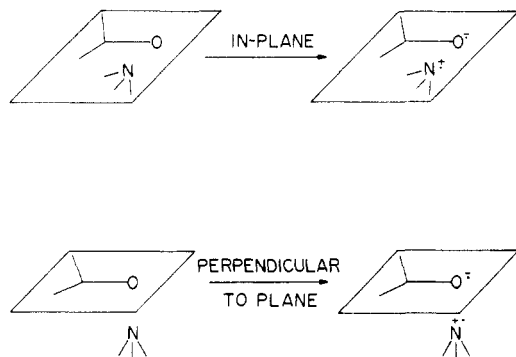

Figure 15. Orientation in electron transfer between a ketone and amine. Approach of reactants may be within a symmetry plane or perpendicular to plane.

in free ions by the technique of time-resolved resonance Raman spectroscopy.²⁵⁹⁻²⁶¹

CIDNP spectral patterns for the quenching of benzophenone by aliphatic and aromatic amines have been explained in terms of radical ion pair transformations.^{262,263} CIDNP signals have also been obtained during the irradiation of solutions of benzophenone derivatives in the presence of triethylamine.²⁶⁴ It was possible to differentiate between the ionic species formed immediately after electron transfer and the neutral radicals resulting from proton abstraction, based upon differences in hyperfine coupling constants of the α - and β -protons of amines.

Having briefly surveyed the evidence used to support electron transfer in excited state-amine reactions, we next explore some aspects of their mechanisms. The initial step involving the formation of the encounter complex reflects the unique structural and stereoelectronic features of the excited-state molecules and quenching amines. Several limiting cases are possible. For sensitizers with π, π^* excited states, the approach of the nitrogen bearing the lone pair electrons is perpendicular to the π -plane of the excited state, whether the latter is an excited planar aromatic or carbonyl molecule; for n, π^* excited states, the encounter may involve an "in-plane" approach (Figure 15).²⁶⁵ A further refinement of symmetry may be incorporated through the use of state correlation diagrams analogous to those employed for photochemical hydrogen abstraction.^{63,265} For example, the correlation diagrams for electron transfer to n, π^* and π, π^* excited states of carbonyl molecules from the n orbital of nitrogen are equivalent to energy surfaces derived for the hydrogen abstraction from alcohols (Figure 16). These correlations predict symmetry-allowed electron transfer to n, π^* states and symmetry-forbidden electron transfer to π, π^* states. Electron transfer is probably marked by abrupt changes in the electronic wave functions at the transition state. The "sudden" changes may result in a switch in the symmetry of the wave functions and promote transitions at "avoided crossings" between energy surfaces.⁶³ Such avoided crossings refer to the "bending" away of the energy surfaces at the geometry corresponding to electron transfer.

Whatever the role or symmetry and orientation, adiabatic electron transfer within the encounter complex gives a solvent-separated radical ion pair or the corresponding exciplex or contact ion pair. These

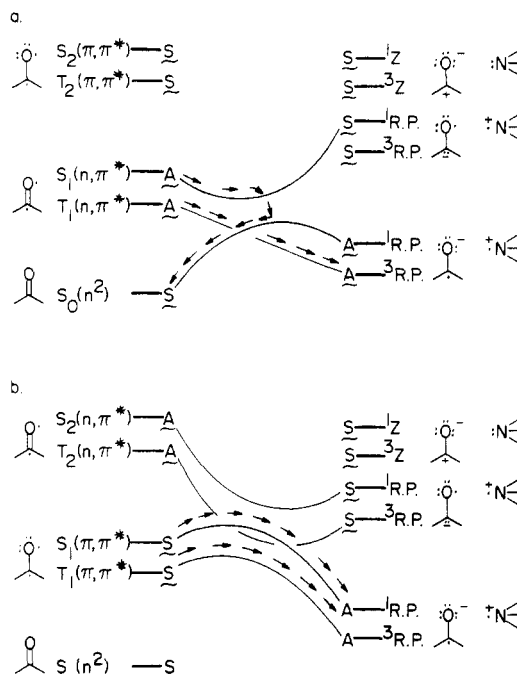
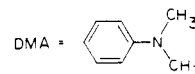
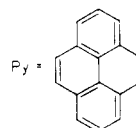
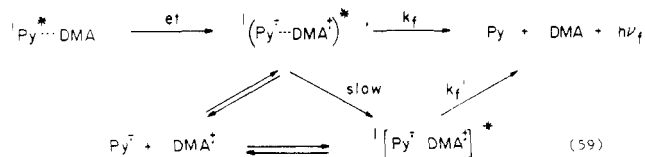

Figure 16. Orbital correlation diagrams for coplanar electron transfer when ketone's lowest excited state is (a) n, π^* or (b) π, π^* . Refer to symmetry plane in Figure 15.

species are destabilized with respect to the solvent molecules in the surrounding shell, and a "slow" re-orientation of solvent molecules eventually results in the formation of a long-lived, stabilized ion pair.⁴⁵

Emission spectroscopy, time-resolved spectroscopy, and transient photoconductivity have been used to unravel the complexities of sensitizer-amine electron-transfer reactions. The following examples emphasize the difficulties in assigning actual mechanisms to fairly complex systems.

One well-known example is the quenching of pyrene fluorescence by *N,N*-dimethylaniline. In moderately polar solvents, the quenching is accompanied by fluorescence emission from the pyrene-dimethylaniline exciplex, as well as a two-component rise in photocurrent.²⁶⁶ The rise in the "slow" photocurrent component is observed only after complete decay of the exciplex fluorescence. The exciplex emission is not observed in polar solvents, and the "slow" photocurrent component is suppressed. These observations might suggest the involvement of two pathways resulting in ionic species according to the equation shown below:^{45,46,118,266-268}



Solvation of charge-transfer intermediates plays a key role in reactions such as 59, although any conclusions to be drawn from the experimental data must be re-

garded as highly tentative. Thus, the existence of multiple, equilibrating contact ion pairs and exciplexes has been suggested by time-resolved conductivity measurements employing picosecond laser pulses. For example, it was observed that the fluorescence decay lifetime of singlet pyrene does not match the photo-current rise time.^{46,251} This observation might be the result of a large number of equilibrating charge-transfer complexes of various structures. A possible reaction sequence is shown below:

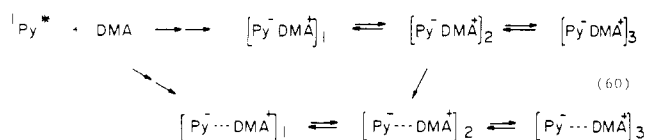

Picosecond time-resolved spectroscopy has been used to study the nature of the intermediates in the photo-reduction of triplet benzophenone by *N,N*-diethylaniline or *N,N*-dimethylaniline. In polar solvents, it has been observed that the spectrum of the benzophenone anion undergoes a blue shift in less than 2 ns after formation.^{252-255,258} A possible sequence may involve initial electron transfer to generate a solvent-separated ion pair, formation of a contact ion pair, and finally proton transfer within the contact ion pair:

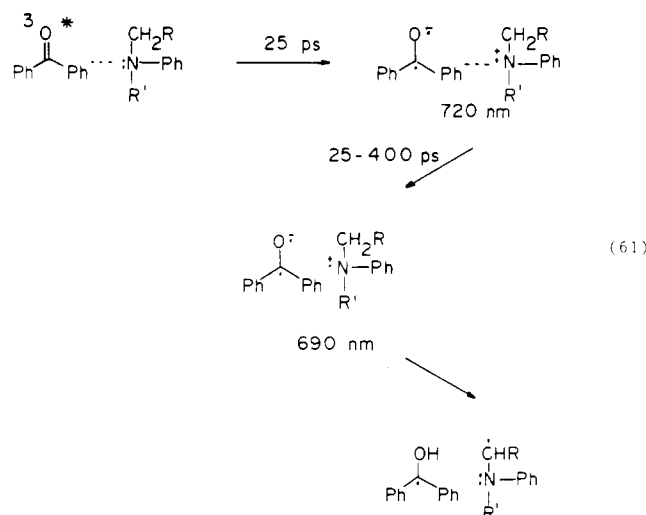

Steric effects have also been investigated for sensitizer-amine reactions. Fluorescence emission studies of naphthalene-amine pairs have revealed interesting effects, based upon the structure of the amine. For example, planar *N*-methylpyrrolidine quenches the fluorescence of naphthalene more efficiently than nonplanar triethylamine.^{22,269} With the latter quencher, it is likely that the nitrogen atom must undergo substantial rehybridization during exciplex formation.

Another approach to the study of sensitizer-amine pairs has involved the use of magnetic field effects.^{99,100,147,148} As stated in section III.D.1, radical ion yields can be influenced by the application of an external magnetic field. Thus, in the pyrene-dimethylaniline pair in acetonitrile, triplet recombination directly from the geminate ion pair to give triplet pyrene is reduced when the reaction is carried out in the presence of a magnetic field of 500 G. This effect can be explained on the basis of the splitting of the degenerate singlet and three triplet states because the magnetic field influence on the hyperfine interactions.³⁴ The result of the energy "splitting" is to reduce tran-

sitions to the triplet states and increase the generation of singlet radical ion pairs. No magnetic field effects are observed for recombination of exciplex ions or free ions because the electron-exchange interaction overwhelms the hyperfine interaction. Magnetic field effects involving free ions are ruled out because hyperfine-induced coherent electron spin motion is virtually lacking between radical ions separated by a large distance.¹⁴

As these experiments suggest, it is possible to identify exciplexes, solvent-separated radical ions, and free ions, based upon their different behavior in magnetic fields.⁹⁹ In the case of solvent-separated and free ions, their recombination reactions take place on different time scales. The applied magnetic field effect can be evaluated in these two time domains by a comparison with "base line" studies where an external magnetic field is absent. Thus, in the example of the pyrene-dimethylaniline system, laser flash spectroscopic measurements show that the appearance of triplet pyrene, pyrene anion, and the amine cations occur from solvent-separated, geminate ions within several nanoseconds and from free ions within several microseconds.

3. Intramolecular Quenching by Electron Transfer

Photoinduced electron transfer has been demonstrated in many molecules where the donor and acceptor are linked together intramolecularly. The efficiency of intramolecular electron transfer is strongly influenced by the separation distance between donor and acceptor and the structure of the molecular link. It is possible to characterize pathways where either donor and acceptor groups can form collision complexes or exciplexes, or exchange an electron at a long distance.

An operational format for intramolecular electron transfer is shown in Scheme IV. Three possibilities are illustrated: intramolecular electron transfer between donor and acceptor molecules separated by a (1) short flexible chain, (2) long flexible chain, and (3) rigid spacer molecule. In pairs held together by flexible chains, the length of the chain, its steric nature, the effect of solvent viscosity and temperature on chain motion, and the solvent dielectric are predicted to influence the conformation of the ground state at the moment of electron transfer, the distance the electron must travel, and the stabilization of exciplex and radical ion intermediates.^{22,269} For example, when the chain is long, consideration must be given to unrestricted conformational motions in the ground state as well as intermediate structures. In Scheme IV, examples are shown where the chain can adopt an "extended" and "folded" conformation. In rigid systems, the situation is less complex. Only the separation distance and orientation of the donor and acceptor need be considered.

In general, in flexible molecules electron transfer is generally favorable when the connecting link is short. In these molecules, exciplexes are possible intermediates when structure allows for orbital overlap between donor and acceptor. Apparently, intramolecular exciplexes do not necessarily have to adopt a mutually planar relationship.^{270,271} For example, it has been noted that in some exciplexes, the donor and acceptor can exist in a perpendicular conformation after excitation.²⁷² The exciplex formed from such a structure is a so-called "twisted" charge-transfer complex.

As more linking groups are placed between the donor and acceptor, exciplex formation becomes less efficient until distances such that the ends of the chain "wrap around" to adopt a head-to-tail, sandwiched structure.²⁷³ Planar exciplexes are thus possible intermediates in large flexible molecules. The rate of their formation, however, can be slow in viscous solvents, which can introduce a "drag" in molecular motion and prevent an effective approach before the decay of the excited partner. In any case, if the viscosity of the solvent hinders exciplex formation, then long-range electron transfer or radiative and nonradiative modes of decay may become competitive.

Solvent stabilization of exciplexes and radical ions also play an important role. The fluorescence of intramolecular exciplexes has actually been observed.²⁷⁴

The importance of the electron-transfer pathway has been confirmed in many intramolecular donor-acceptor pairs, including aromatic hydrocarbon-amine, porphyrin-amine, ketone-amine, ketone-olefin, and coupled binuclear metal pairs. Time-resolved fluorescence emission, picosecond flash spectroscopy, and ESR have provided the proof of electron transfer, as well as a better understanding of the mechanistic details.²⁷⁵⁻³⁰²

a. Aromatic Hydrocarbon-(CH₂)_n-Amines: The Role of Exciplexes and Radical Ions. Fluorescence spectral studies have confirmed the key role of charge-transfer exciplexes formed from intramolecular aromatic hydrocarbon-amine pairs. The naphthalene fluorescence in naphthalene-(CH₂)_n-amine molecules is quenched efficiently for $n = 1-4$.²⁷⁵ Exciplex emission can be observed in polar and nonpolar solvents. This emission "peaks" in intensity for $n = 2$ and 3, suggesting a more favorable "in-line" approach of the lone pair electrons of the amine and π -orbitals of naphthalene:

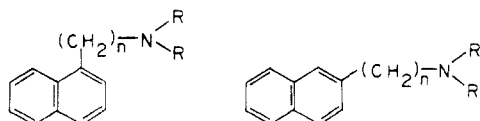

$n = 1-4$; solvents: benzene, cyclohexane, acetonitrile

Fluorescence exciplex emission has also been reported in a series of ω -1-naphthyl-(CH₂)_n-*N*-alkylpyrroles.²⁷⁶ The intensity of exciplex emission is greatest for $n = 2$:

n	ϕ_f
0	0.05
1	0.03
2	0.36

In this example, the rate of appearance of fluorescence (fluorescence rise time) is greatest for $n = 0$ and 1, as might reasonably be expected from the effect of distance on the rate of electron transfer. However, the prediction that the exciplex emission lifetime should decrease for $n = 2$ in more polar solvents (where formation of radical ions is likely) is not fulfilled. This observation may be a reflection of the opposing tendencies of the polar solvent to stabilize an intramolecular exciplex and aid in its dissociation.

Studies employing time-resolved fluorescence and

laser flash spectroscopy on 2-anthracene carboxylic ester-(CH₂)_n-dimethylamine pairs give an excellent demonstration of the effects of chain length and solvent polarity:²⁷⁷

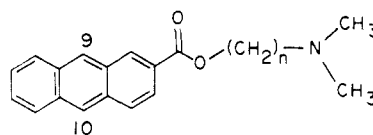

n	k_{et} (s ⁻¹) in CH ₃ CN
2	1.4×10^8
3	0.8×10^8
5	1.6×10^8
9	5.2×10^8
11	4.1×10^8

The ester group maintains a distance of about 4 Å between the first methylene group and the aromatic ring, because it is coplanar with anthracene. In methylcyclohexane, quenching is observed only for $n = 9$ and 11 and is accompanied by a weak exciplex emission. Presumably, the aliphatic amine nitrogen can coil closely to carbons 9 and 10 of the central ring in anthracene where charge density is greatest. In acetonitrile, however, no exciplex emission can be detected. Nevertheless, quenching is efficient for all n . This observation suggests that electron transfer to generate radical ions is important and can take place over long distances.

A picosecond laser flash study of anthracene-(CH₂)₃-dimethylaniline has confirmed the existence of two ground-state conformers in the pathway of electron transfer.²⁷⁸ A weak and short-lived emission of its exciplex has been observed in acetonitrile. The formation of this exciplex is rapid (less than 2 ps) but does not match the decay of the excited anthracene molecule (measured to be 7 ps). It is possible that two pathways of electron transfer are taking place. The first is electron transfer between the donor and acceptor in an extended conformation resulting in the direct formation of a radical ion pair; the second is electron transfer in the folded conformation favoring exciplex formation:

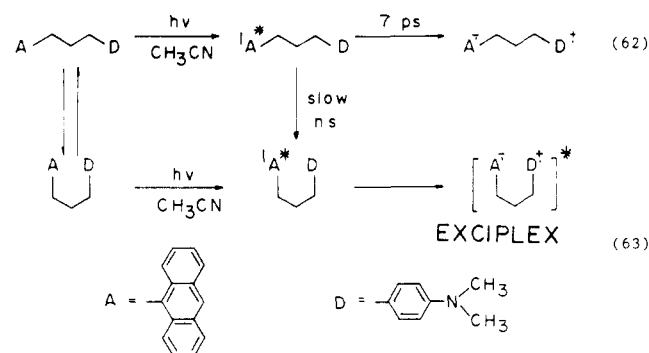

In nonpolar solvents, intramolecular exciplex formation is, as a rule, relatively slow, as shown in the above example.^{278,279} The relatively slow chain motions and internal rotations are rate-determining in formation of the head-to-tail exciplex from the extended conformation. Once the exciplex is formed, however, it is long-lived because dissociation into radical ions is endothermic under nonpolar solvent conditions.

The variation in chain length has been systematically

studied by picosecond spectroscopic techniques for 1-pyrenyl- and 9-anthracyl-(CH₂)_n-dimethylamine pairs in a variety of solvents.^{46,280,281} The fluorescence of intermediate exciplexes can be observed in polar and nonpolar solvents for *n* = 1–3. The pair separated by three methylene units displays dynamic behavior in several solvent systems. The rise time of the transient absorption spectrum of the exciplex and its fluorescence decay take place in the nanosecond domain in nonpolar solvents, such as hexane. In acetonitrile, however, exciplex formation is complete within a few picoseconds. In a solvent of intermediate polarity and relatively high viscosity such as 2-propanol, two time-dependent transient absorption spectra are detected. The first appears within 350 ps and is replaced by the slow (1 ns) appearance of another absorption spectrum. A possible reaction scheme to explain these observations is shown below.²⁸¹

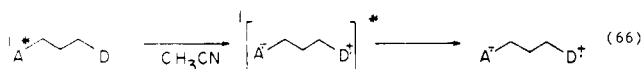
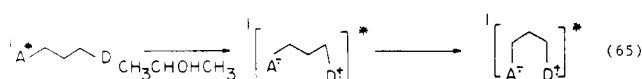
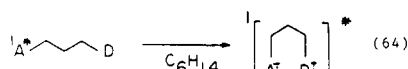

These observations stress the critical role of dynamic conformational motion in nonpolar solvents. In contrast, electron transfer in polar solvents usually occurs faster than dynamic conformational motions in these solvents.

Intersystems crossing in intramolecular systems is closely tied in with the dynamic behavior of radical ions and exciplexes. For example, triplet pyrene has been detected by its time-resolved absorption spectrum following the laser flash photolysis of 1-pyrenyl-(CH₂)_n-amine pairs.²⁸² Its appearance can be explained by a triplet recombination pathway:

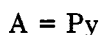
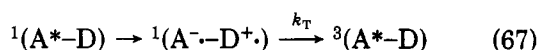

k_T is the rate of intersystem crossing within the initially formed singlet exciplex to generate triplet pyrene. Of particular interest are the effects of structure and solvent polarity on *k_T*:

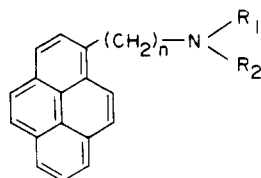
	<i>n</i>	<i>R</i> ₁	<i>R</i> ₂	<i>k_T</i> (s ⁻¹)
	1	CH ₃	CH ₃	8 × 10 ⁸
	1	H	C ₆ H ₅	2.7 × 10 ⁸
	2	H	C ₆ H ₅	< 4 × 10 ⁸
	3	H	C ₆ H ₅	< 3 × 10 ⁸
	1	CH ₃	C ₆ H ₅	4.3 × 10 ⁸

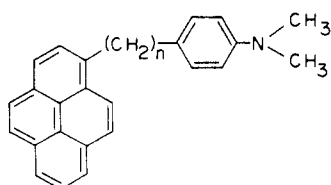
	<i>n</i>	<i>k_T</i> (s ⁻¹)
	1	1 × 10 ⁸
	2	1 × 10 ⁸

For *n* = 1, it has been proposed that the π-orbitals of pyrene and the lone pair electrons of the amines are aligned in a mutually perpendicular orientation, and this allows for effective spin-orbital coupling and results in larger *k_T* values.²⁸² The sandwiched structure, which is a likely intermediate for *n* = 3, is probably not as effective in inducing intersystems crossing, as can be deduced by its lower *k_T*. The change in orbital angular momentum necessary for a spin-flip is not present when the orbitals are aligned in a parallel direction. *k_T* is also larger in nonpolar solvents—a result explained by the possible intermediacy of structurally “compact” exciplexes. Polar solvents may favor more “loosely held” structures in which the orbital interactions required for intersystems crossing are weaker.

b. Porphyrin–Quinone Systems: The Effects of Distance and Orientation. The detection of charge-transfer intermediates following the excitation of porphyrin–quinone intramolecular pairs is possible in systems where the chain or spacer molecule holding the porphyrin and quinone retards reversible electron transfer.²⁸³ An example is the quenching of tetraphenylporphyrin linked to a quinone by a peptide chain:²⁸⁴

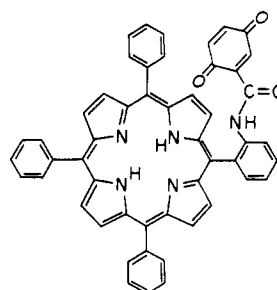

It has been shown that upon excitation, porphyrin fluorescence is quenched efficiently. Direct evidence for electron transfer has been obtained for intramolecular porphyrin-(CH₂)₃-quinone, where the ESR spectra of the radical ion products have been recorded.²⁸⁵

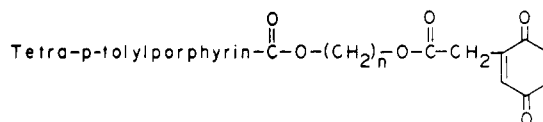

n = 2, 3, 4

ESR and fluorescence spectroscopic have helped to establish the critical role of the geometry of the flexible chain in porphyrin–quinone systems.^{286,287} For example, time-resolved fluorescence studies have confirmed that electron transfer is most rapid for *n* = 3 (*k_{et}* exceeds 10⁸ s⁻¹). For *n* = 3, it is likely that electron transfer proceeds via the intermediacy of a folded structure. Similar studies have been carried out on other intramolecular porphyrin–quinone pairs.^{288,289}

Picosecond transient absorption and fluorescence decay studies on porphyrin-(CH₂)_n-benzoquinone systems have given evidence of a clearcut decrease in *k_{et}* with increase in chain length (*k_{et}* > 10¹¹ s⁻¹, *k_{et}* ~ 10¹⁰ s⁻¹, *k_{et}* ~ 10⁹ s⁻¹ for *n* = 2, 4, 6, respectively).²⁹⁰ This result is as predicted from the exponential dependence of the rate of electron transfer on distance, since extended conformations are more probable for *n*

> 3. However, the rate is only slightly sensitive to solvent polarity. This result is in sharp contrast to the solvent effects noted in aromatic hydrocarbon-amine pairs, where solvent polarity has a large effect on k_{et} .

Studies on porphyrin-quinone systems held together by rigid spacer molecules have raised some interesting questions. In these examples, conformational motions which invariably introduce complexities are absent. In rigid systems, it is possible to define a static conformation and separation distance and thereby determine the effect of distance and structure on the rate of electron transfer without the complexities of dynamic motion found in flexible systems. An absorption spectrum of a charge-transfer state has been obtained following laser flash photolysis of a porphyrin linked to a quinone at a center-to-center distance of about 10 Å.²⁹¹ Both singlet and triplet porphyrins are capable of electron donation over this distance.

Transient absorption spectra have also been measured for the quenching of zinc tetraphenylporphyrin linked rigidly to various quinones by a triptycentyl structure:²⁹²

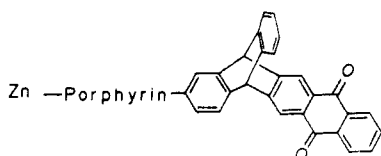

The charge-transfer products are formed in rather high yield following the efficient quenching of the porphyrin fluorescence. This interesting result suggests that stacked, sandwiched geometries between the porphyrin and quinone are not a requirement for efficient electron transfer.

The effect of distance has been probed in porphyrin-quinone pairs separated by rigid bicyclooctane spacer molecules.²⁹³ The rates of electron transfer, measured from the porphyrin fluorescence lifetimes, clearly decrease with separation distance, again confirming the critical role of distance:

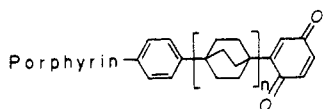

Studies of the effect of distance on electron transfer have not been limited to porphyrin-quinone pairs. For example, rapid electron transfer ($k_{et} > 10^{11} \text{ s}^{-1}$), accounts for the quenching of methoxybenzene fluorescence in the following rigid molecule:²⁹⁴



In this molecule, the center-to-center distance is estimated as 7.5 Å.

As has already been mentioned in another context (section II.C.9), long-range electron transfer has been measured for donor-acceptor groups separated by about 10 Å in rigid steroids.^{94,295} This result illustrates that electron transfer is possible ($k_{et} = 10^6\text{--}10^9 \text{ s}^{-1}$) over long distances and does not require the intermediacy of a collision complex. It has recently been suggested that rapid, long-range electron transfer in intramolecular systems may be due to favorable solvent reorganization factors.²⁹⁶

It is interesting to note that triplet-triplet energy transfer can proceed at much slower rates in intramolecular systems. For example, the rate of energy transfer from the lowest triplet states of benzophenone or carbazole to naphthalene in rigid intramolecular systems is 25 and 0.04 s^{-1} , respectively.^{297,298} The dramatically significant difference between rates of electron and energy transfer in these systems may reflect different structural and orientational requirements between the two pathways. In energy transfer by electron exchange, unusual electronic or nuclear factors may also account for the slow rates.

If electron transfer can occur between widely separated molecules, what is the nature of the mechanism? Is the transfer of an electron between widely separated groups a result of a through-space or through-bond interaction? A through-space pathway is clearly a preferred mechanism in flexible systems where some orbital overlap is allowed (exciplex pathway). But if overlap is not possible because of structural restrictions, then electron transfer via through-bond coupling of the donor-acceptor orbitals with the σ -orbitals of the intervening spacer is a possible pathway. Through-bond coupling between donor and acceptors separated by as many as five bonds has been deduced by the appearance of intramolecular charge-transfer absorption and emission.²⁹⁹

Although evidence to establish the role of through-bond coupling in long-range electron transfer at this state is difficult to obtain,³⁰⁰ it does serve as an attractive explanation. This mechanism may help to explain why electron transfer takes place so rapidly between widely separated molecules. Through-bond coupling in photochemical systems is analogous to the "inner-sphere" electron-transfer pathway proposed by Taube (section II.C.11). It is possible that the symmetry of the orbitals in the donor and acceptor as well as the spacer should play an important role.³⁰¹ Clearly, more investigations are necessary to understand the complexities introduced by long-range interactions.

c. Electron Transfer in Intramolecular Ketone-Amine Systems. The requirement for maximum orbital overlap between the nitrogen n -orbital and the excited carbonyl group in intramolecular ketone-amine systems is apparently important for efficient electron transfer in these systems. For this reason, the rates of electron transfer normally proceed more slowly than intermolecular reactions.²⁴⁰ Studies on the effect of chain length in flexible systems of carbonyl groups and electron donors illustrate this point. Quenching of ketone triplet states is efficient only for larger chains which allow for more effective overlap of donor-acceptor orbitals. Intramolecular electron-transfer quenching of amino ketones separated by only one carbon group is least efficient.

In the intramolecular quenching of excited ketones by alkenes, electron transfer is preceded by a ground-state conformational change which brings the π -orbitals of the double bond into effective overlap with the half-vacant orbital of the excited ketone.^{302,303}

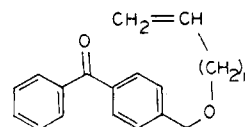

Phosphorescence quenching of the triplet ketone takes place only if $n = 8$, which follows from the fairly strict conformational requirements for these systems.

That geometry plays an important role is also confirmed by studies which have demonstrated clearcut differences in electron transfer reactivity of n, π^* and π, π^* states. For example, the n, π^* states of *p*-acylbenzoate esters react slowly compared with π, π^* states:³⁰³

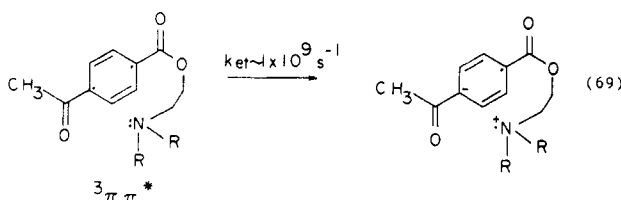
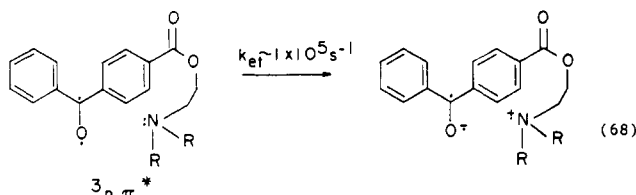

The stereoelectronic configuration of each state plays a special role in this example. In the case of π, π^* states, electron transfer takes place between the amine and aromatic orbitals with greatest overlap.

The quenching of ketone triplet states by phenyl groups in the position also depends on the electron configuration.³⁰⁵ In β -phenylpropiofenone, the triplet lifetime is 0.89 ns in benzene, compared to a triplet lifetime of 50 ns of β -phenyl-4'-methoxypropiofenone in the same solvent. The increase in electronic density of the latter's π, π^* state and the difficulty of forming a sandwiched structure between the orbitals of benzene and the carbonyl group may account for these differences. The half-filled n orbital of the lowest n, π^* state of β -phenylpropiofenone is more electron deficient and can adopt a perpendicular arrangement with respect to the phenyl ring:³⁶⁵

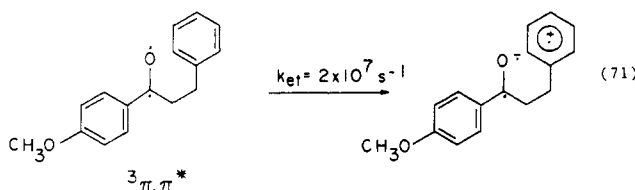
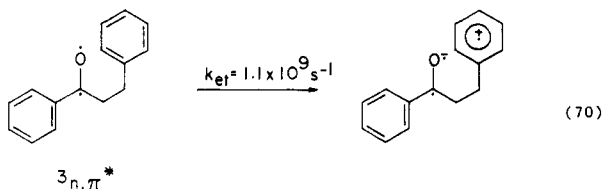

Picosecond laser-induced formation of charge-transfer intermediates of intramolecular benzophenone-(CH_2) $_n$ -dimethylaniline have been observed in polar solvents at low temperatures.^{306,307} In these systems, broad and structureless emission from both singlet and triplet exciplexes has been observed. Singlet exciplex formation is a likely possibility when the molecule is in a folded conformation and accounts for the appearance of a short-lived fluorescence. Phosphorescence of

benzophenone and phosphorescence of a new charge-transfer complex (triplet exciplex) are observed. These results can be explained by invoking dynamic conformational motions. For example, following direct excitation of the "extended" molecule to give singlet benzophenone, intersystem crossing its triplet state competes with folding into a singlet exciplex. The triplet state can undergo phosphorescence or, at slightly higher temperatures, fold to give a triplet exciplex. These results are summarized below for a pair separated by three methylene groups:

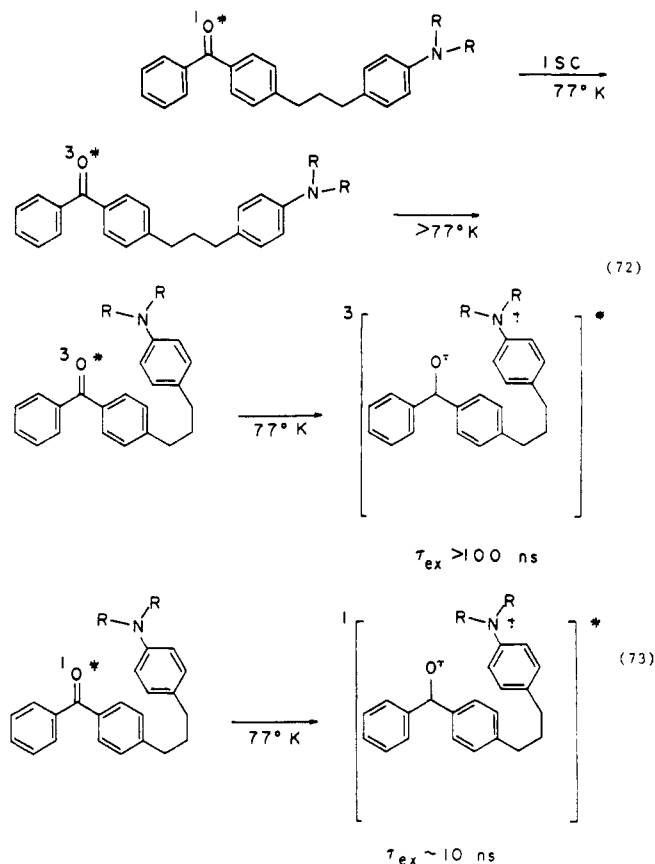

d. Intramolecular Electron Transfer between Bridged Metals. Photoinduced intramolecular electron transfer between metals coupled by ligands with π -delocalized electronic structures is well documented.^{308,309} Excitation of mixed valence and strongly coupled molecules leads to so-called inner-sphere "optical charge-transfer transitions":^{310,311}

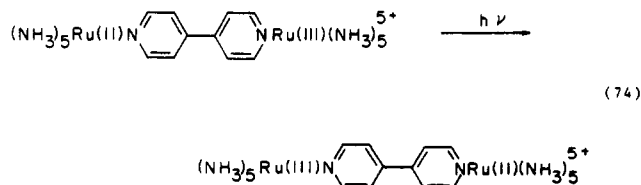

If the bridging ligand is an alkane, long-range electron transfer is to be observed. Picosecond laser photolysis of Cu(I) bridged to Co(III) by an aminoalkane chain leads to a metal-to-ligand charge transfer state [Cu(d)-olefin (π^*)], from which electron transfer occurs in less than 10 ns.³¹²

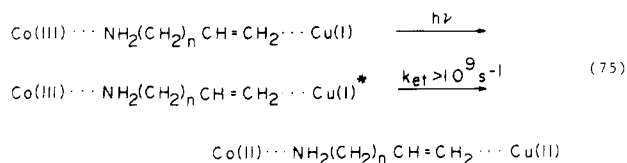

The efficiency of electron transfer decreases with increasing chain length and approaches zero for $n > 5$. Extension of the chains to five methylene units results in electron transfer across a distance of 9.7 Å, which, on the scale of these experiments, appears to be the greatest distance where electron transfer.

Electron transfer between binuclear metal ions linked by bicyclic rigid ligands where the intermetal distance is defined have also been studied.³¹² In the examples shown below, the quantum yield of electron transfer from Cu^+ to the ligand is greater for the endo isomer ($\phi = 1.0$) than for the exo structure ($\phi = 0.6$). The endo isomer can exist as two conformations, and electron transfer may be enhanced because of shorter donor-acceptor separation distances in these structures:

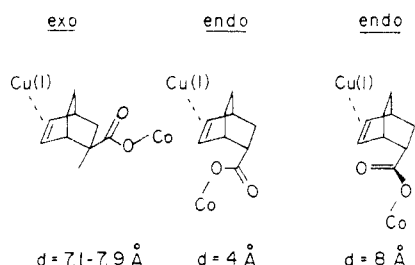

e. Electron Hopping in Intramolecular Systems.

Electron transfer in intramolecular systems where the excited chromophore is consecutively attached to two or more donor or acceptor moieties raises the interesting possibility of "electron hopping" (Scheme V). In the electron-hopping mechanism, an electron proceeds from the donor to an acceptor via a series of consecutive "hops" to various acceptor groups. This mechanism plays a crucial role in the primary stages of photosynthesis where consecutive electron transfer takes place.

Electron hopping in interfunctional organic molecules is well documented.³¹³ For example, studies employing emission spectroscopy have suggested the possibility of electron hopping in aromatic hydrocarbon-diamine molecules:²²

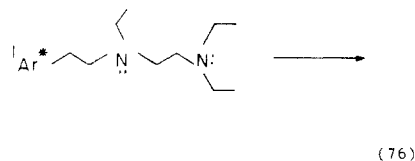

Intermolecular exciplexes have also been invoked to explain the fluorescence data of the following species:³¹⁴

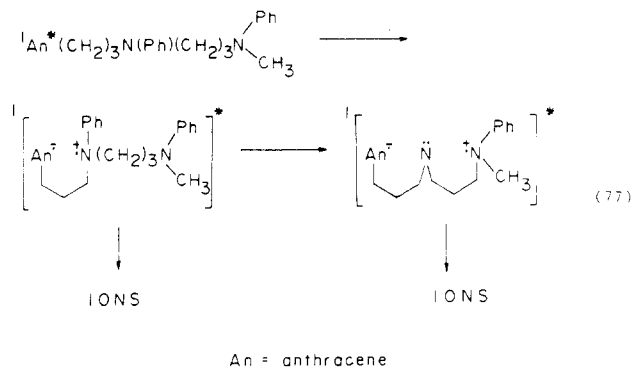

In polar solvents, the fluorescence emission from the exciplex decreases significantly due to the formation of radical ions (note both that a "binary" and "ternary" exciplex are proposed in this example).

Charge-transfer emission following two successive electron transfers has been observed in the following system:^{315,316}

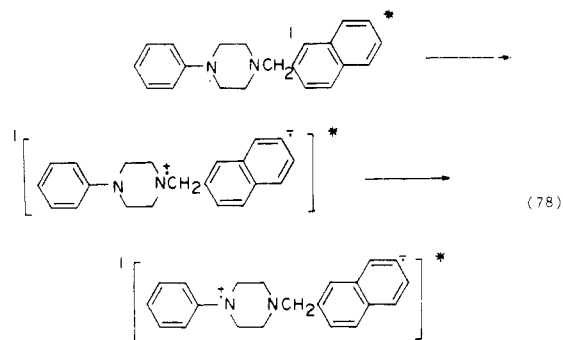

A particularly interesting facet of this example is that quenching of naphthalene fluorescence takes place even upon selective protonation of the central nitrogen atom. This observation may be the result of a "switching" from an electron-hopping mechanism to long-range electron transfer:

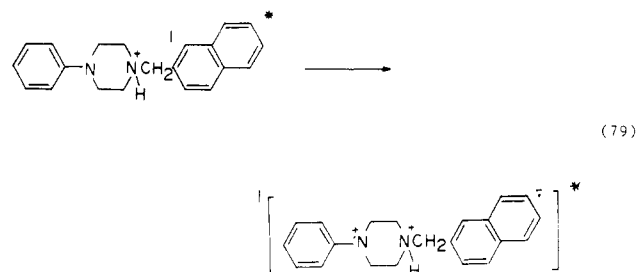

Picosecond spectroscopic studies have confirmed electron hopping in interfunctional molecular porphyrin-quinone systems.^{46,290}

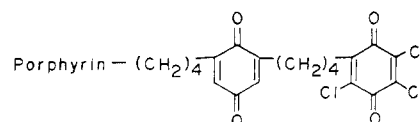

Successive electron transfer has been observed in a centrally located porphyrin attached to a quinone and carotenoid:³¹⁷

TABLE XX. Thermodynamic and Kinetic Parameters of Reactions between Electron-Deficient Sensitizers and Electron-Rich Olefins^a

reaction	ΔG , kcal/mol ^b	k_q , M ⁻¹ s ⁻¹	ref
$^1\text{CN}^* + 1,1\text{-DPE} \rightarrow \text{CN}^- + 1,1\text{-DPE}^+$	-8.8	1.3×10^{10}	139
$^1\text{CN}^* + 1,1\text{-DPE} \rightarrow \text{CN} + ^11,1\text{-DPE}^*$	>~8		
$^1\text{CN}^* + \text{indene} \rightarrow \text{CN}^- + \text{indene}^+$	-15.5	1.1×10^{10}	325
$^1\text{CN}^* + \text{indene} \rightarrow \text{CN} + ^1\text{indene}^*$	>~3		
$^1\text{TPBF}_4 + \text{indene} \rightarrow \text{TPBF}_4^- + \text{indene}^+$	-29.5	$\sim 10^9\text{-}10^{10}$	322
$^1\text{TPBF}_4 + \text{indene} \rightarrow \text{TPBF}_4 + ^1\text{indene}^*$	>27.0		
$^3\text{CN}^* + \text{indene} \rightarrow \text{CN}^- + \text{indene}^+$	16.6		
$^3\text{CN} + \text{indene} \rightarrow \text{CN} + ^3\text{indene}^*$	2.5		

^a In CH₃CN or aqueous solvents. ^b ΔG for electron transfer calculated from eq 17.

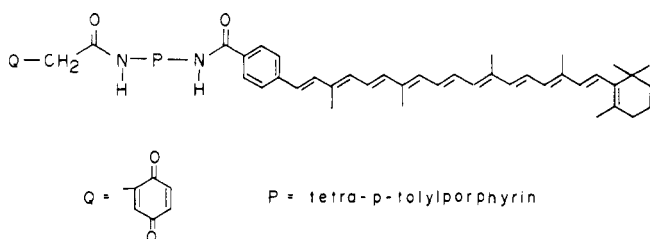

The initial step is electron transfer between the porphyrin and quinone, followed by a second electron transfer between the carotenoid and the porphyrin:

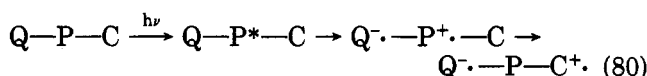

A transient absorption of the carotenoid cation is observed within 100 ps after excitation of the porphyrin.

C. Reactions Photosensitized by Electron Transfer

We now turn to photosensitized electron-transfer reactions. The objective here will be to cite selective examples involving organic substrates where the experimental evidence strongly supports the nature of the electron-transfer mechanism. We shall not attempt to include an exhaustive compilation of the considerably large number of examples which have appeared in the literature since the early 1970s. For comprehensive discussions of the diversified chemistry of photosensitized electron transfer, the interested reader is referred to several excellent reviews.^{19,25}

1. Reactions of Alkenes

The most clearcut examples of electron-transfer photosensitizations are those reactions involving electron-deficient sensitizers and electron-rich olefins (Table XX). The radical cations generated from these reactions have been shown to undergo polymerizations, dimerizations, cross-cycloadditions, nucleophilic substitutions, and isomerizations.^{23,25,141,318-328} The key to the synthetic utility of these reactions lies, for the most part, in the favorable thermodynamics of the primary electron-transfer step. From an inspection of the energy and kinetic parameters in Table XX, it is immediately evident that electron transfer in these systems is thermodynamically and kinetically favorable. These reactions proceed generally at diffusion-controlled rates. Energy transfer is rarely a competitive process, given

the high-lying singlet and triplet states of alkenes. Additional evidence that the primary step involves charge-transfer is given by k_q vs. ΔG plots and product and solvent studies.²⁵ The radical cations formed by quenching are usually quite reactive and undergo secondary electron-transfer reactions, including the formation of stable products. Thus, photolysis of acetonitrile solutions of indene derivatives in the presence of deficient sensitizers gives good yields of *exo*-head-to-head dimers:^{322,323}

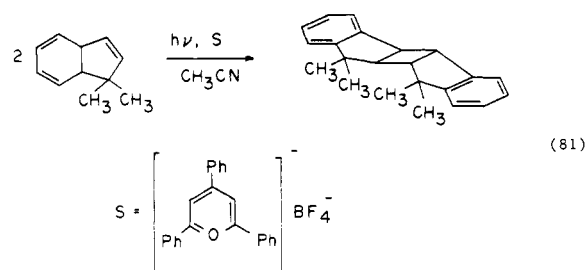

The formation of *exo*-head-to-head dimers is compatible with the intermediacy of the radical cation of indene. Ring closure to the *exo* dimer is sterically favored:

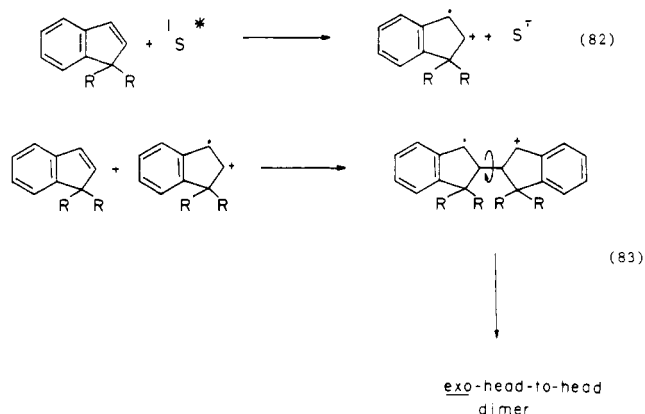

Further proof supporting the role of electron transfer is given by the observation that the dimerization of 1,1-dimethylindene can be effectively suppressed in the presence of quenchers with low oxidation potentials.³²³

Mixed addition products have been reported in the photolysis of solutions containing sensitizer, indene, and olefins with high oxidation potentials. For example, in the presence of phenyl vinyl ether or furan, [2 + 2] cycloaddition products are formed as well as small amounts of homodimers.^{25,324,325}

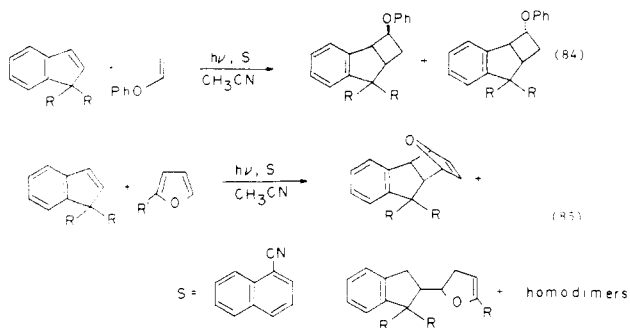

Several pathways must be considered to explain the products. The major pathway apparently involves electron abstraction from the olefin with the lower oxidation potential:

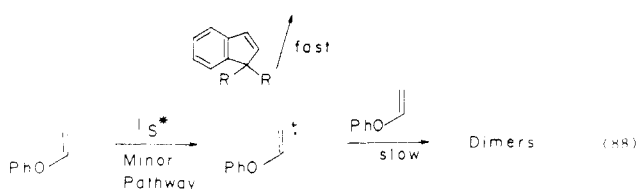
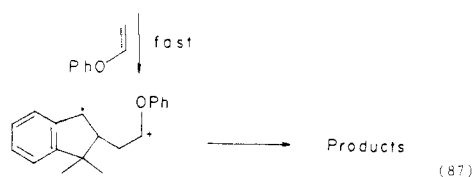
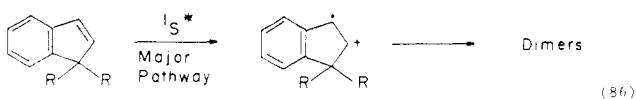

“Anti-Markovnikov” addition products have been reported for the photosensitized reactions of 1,1-diphenylethylene in the presence of nucleophiles such as alcohols or cyanide:^{139,140,326,327}

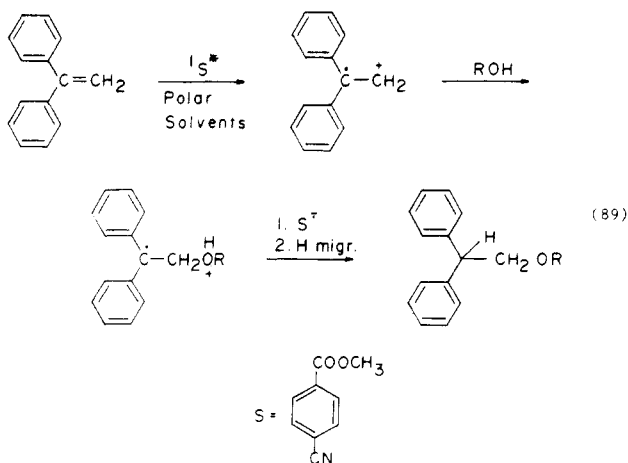

In acetonitrile, the dimerization of 1,1-diphenylethylene has been reported to be photosensitized by methyl *p*-cyanobenzoate.³²⁶ Minor amounts of an oxetane are also formed by cycloaddition between the sensitizer and the olefin:

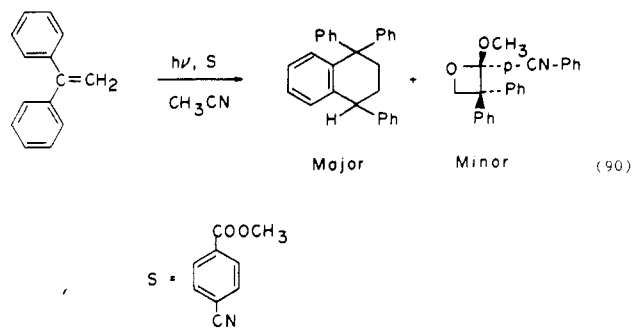

Support for radical ion intermediates has been furnished by a successful attempt to observe the 1,1-diphenylethylene cation by ESR in polar solvents. In a less polar solvent such as benzene, no dimeric products are observed; the oxetane is the major product:

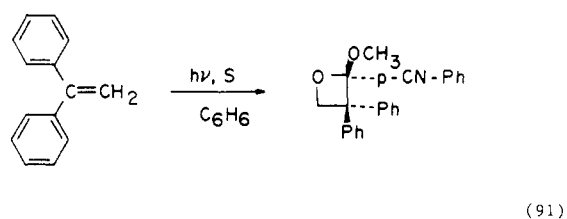

In benzene, it appears that the primary quenching reaction results in the formation of a “tight” complex between the sensitizer and the olefin. Bond formation within the exciplex or contact ion pair to give the oxetane is more favorable than separation into solvent-separated or free ions. In more polar solvents, the charge-transfer complex rapidly dissociates into ions, which subsequently take part in dimerization.

The trapping of geminate ion pairs before subsequent dissociation has in fact been reported.³²⁸ In acetonitrile, 1,1-diphenylethylene quenches the excited singlet state of 2,6,9,10-tetracyanoanthracene to give three addition products:

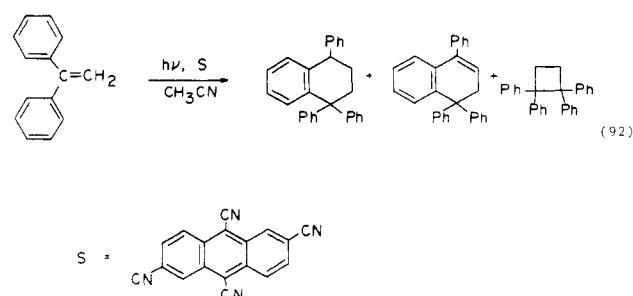

Formation of 1,1,2,2-tetraphenylcyclobutane is favored at high olefin concentrations, a result which implies that two distinct radical ion pairs are formed:

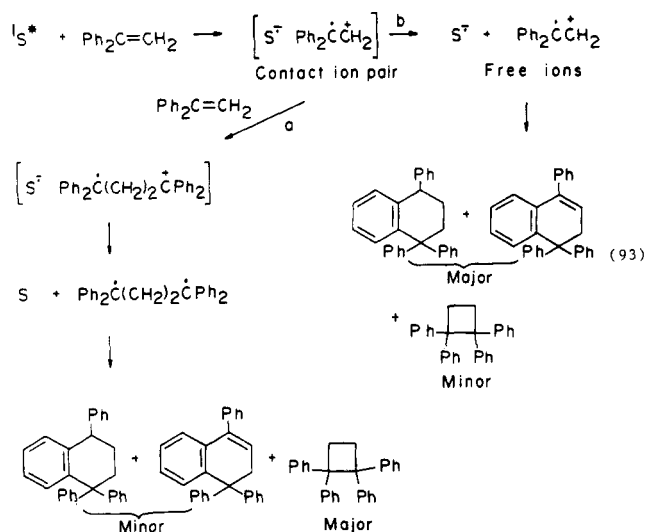

Interception of the geminate cation by 1,1-diphenylethylene (pathway a) is rapid ($\sim 10^{10} \text{ s}^{-1}$). Reversible electron transfer between spin-correlated radical ions in close proximity is rapid and ultimately leads to the cyclobutane product. Pathway b, the dissociation of the geminate ions, is favored only at low olefin concentrations.

Although these experiments do not define precisely the structure of the geminate ion pair, they underscore the importance of separation distance in determining product distribution. Thus, reversible electron transfer is an important pathway when radical ions are separated by only a small distance, and this feature can have ramifications when planning synthetic schemes. Similar results have been reported for the photosensitized reactions of phenylacetylene.³²⁹

Several examples of electron-transfer photosensitizations of olefins in the presence of cosensitizer have appeared in the literature. The photoinitiated dimerization of indene can take place in the presence of two sensitizers, phenanthrene and *p*-dicyanobenzene.¹⁴⁴ Phenanthrene is the light-absorbing sensitizer. Its singlet state is quenched by *p*-dicyanobenzene, an electron acceptor, resulting in the formation of radical ions. The evidence for radical ions has been furnished by laser spectroscopy. *p*-Dicyanobenzene functions as a cosensitizer:

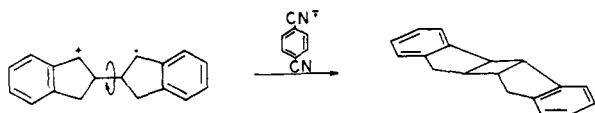
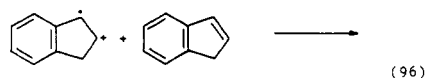
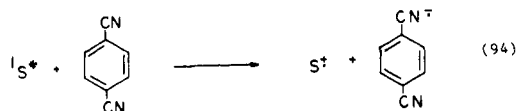

2. Bond Cleavages, Ring Openings, Eliminations, and Isomerizations

Strained cyclic organic molecules are efficient quenchers of excited states. These reactions frequently involve electron transfer. For example, naphthalene

fluorescence can be efficiently quenched by strained cyclic molecules.¹⁰⁸ The inherent charge-transfer nature of the mechanism is confirmed by the excellent correlations between $\log k_q$ and the oxidation potentials of a series of saturated cyclic hydrocarbons. Photolysis of methanolic solutions of tricyclo[4.1.0]heptane and 1-cyanonaphthalene leads to CH_3OH addition:¹⁰⁸

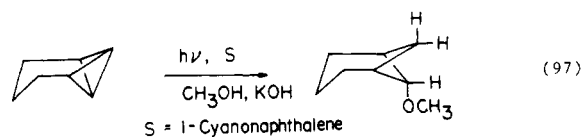

The mechanism involves the formation of a radical ion pair, following primary electron-transfer quenching:

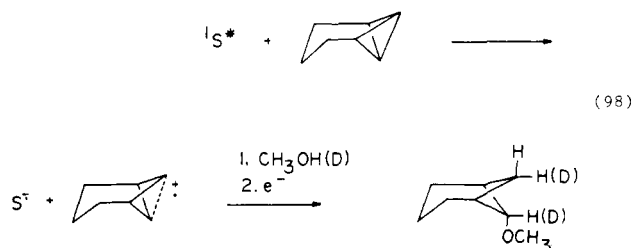

Nucleophilic attack on the radical-cation intermediate precedes electron donation from the 1-cyanonaphthalene anion. Deuterium experiments demonstrate 100% incorporation of the methanolic hydroxyl proton.

N,N,N',N'-tetramethylbenzidine (NTMB) has been shown to be an effective sensitizer of ring-opening reactions, bond cleavages, and cis-trans isomerizations.³³⁰⁻³³² The excited singlet and triplet states of this sensitizer are electron donors and can be quenched at diffusion-controlled rate constants in the presence of electron acceptors. In the presence of NTMB, photolysis of solutions containing aryl pinacol carbonates leads to decomposition of the substrates:³³⁰

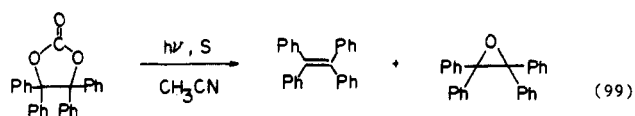

S = *N,N,N',N'*-tetramethylbenzidine

Similarly, benzyl esters have been reported to undergo electron-transfer photosensitized decompositions:³³¹

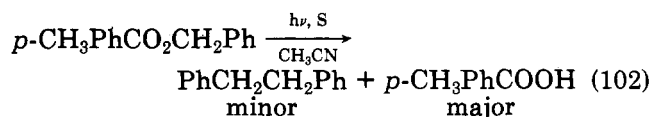
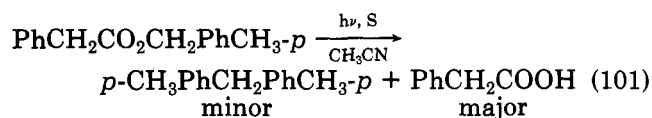
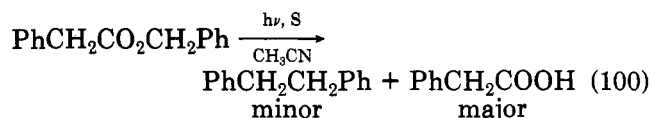

S = *N,N,N',N'*-tetramethylbenzidine

Photolysis of acetonitrile solutions of NTMB and dibenzylsulfone leads to SO₂ extrusion:³³²

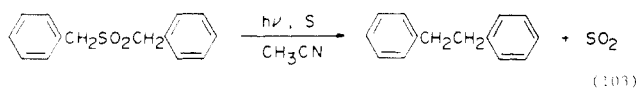

S = N,N,N',N'-tetramethylbenzidine

Another example is the sensitized cis-trans isomerization of stilbene oxides:³³²

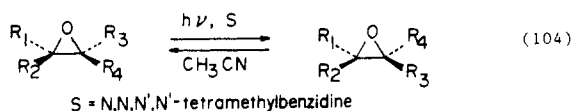

Evidence for an electron-transfer mechanism in reactions 99–104 is based upon (1) thermodynamic considerations (energy transfer to the n, π^* state of the quenchers is excluded because of the high energy of n, π^* states), (2) the observation of the transient absorption spectrum of NTMB⁺ obtained from laser photolysis experiments, (3) quantitative recovery of NTMB, and (4) a photostationary state rich in the trans isomer in reaction 104. The results are explained in terms of reactions within a charge-transfer complex or solvent-caged radical pair. For example, ring-opening in the radical ion pair is presumed to be a key step in the decomposition of cyclic carbonates:

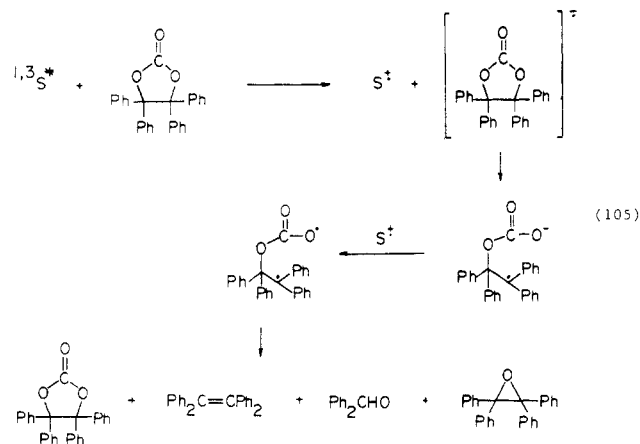

In the reactions of benzyl esters, bond cleavage can result from the radical anions of the esters and their neutral radicals formed by reversible electron transfer within the solvent cage:

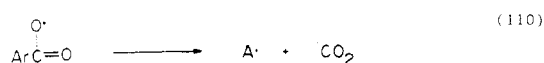
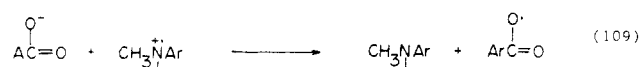
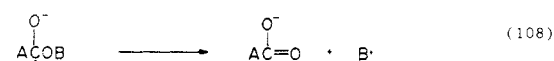
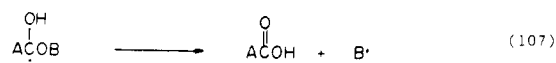
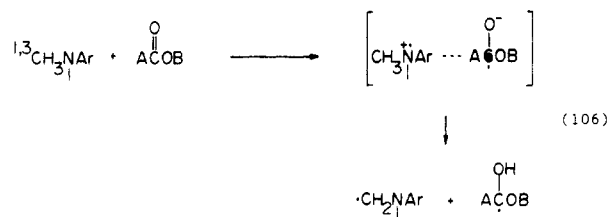

Similarly, the extrusion of SO₂ from dibenzyl sulfone is proposed to follow formation of a charge-transfer complex:

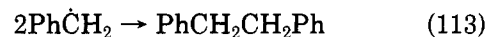

DBS = dibenzyl sulfone

Several experimental lines of evidence argue for charge-transfer complexes rather than free ions: (1) the sensitivity of transient NTMB⁺ yield to changes in solvent polarity; (2) the observed inefficiency of bond cleavage. Presumably, reversible electron transfer within the charge-transfer complex competes effectively with bond cleavage. The quenching of triplet NTMB leads to more efficient bond cleavage, as would be predicted for the generation of triplet radical ion intermediates.

Sensitized bond cleavage reactions of 1,2-diarylethanes and arylpinacols have recently been reported.³³³ For example, in the presence of O₂, substituted bibenzyls quench the fluorescence of singlet 1,4-dicyanonaphthalene at diffusion-controlled rates to give aldehydic products:

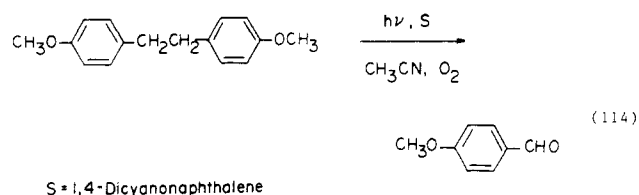

The mechanism is thought to involve bond cleavage of the radical cation of the substrate, followed by reaction of oxygen with one of the radical fragments:

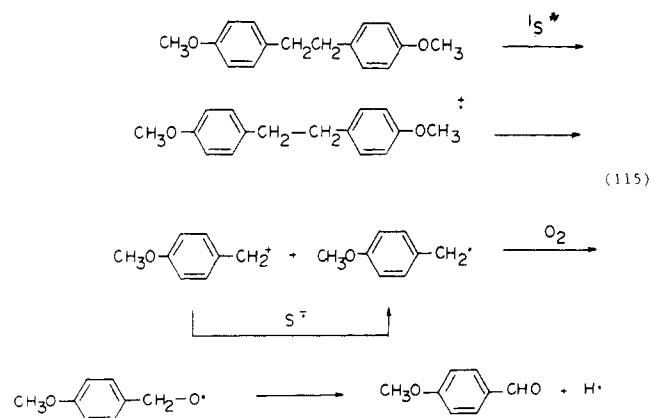

Time-resolved laser spectroscopy has provided evidence of the transient radical anion of 1,4-dicyanonaphthalene, thus confirming the electron-transfer pathway.

Pinacol derivatives also undergo bond cleavage in the presence of singlet 1,4-dicyanonaphthalene:³³³

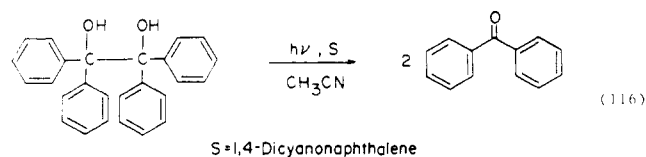

The efficiency of the above reaction is enhanced in the presence of O_2 because of formation of $O_2^{\cdot-}$ by electron transfer (section IV.C.4):

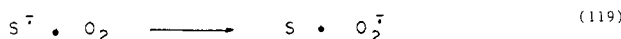
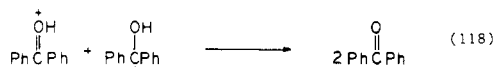
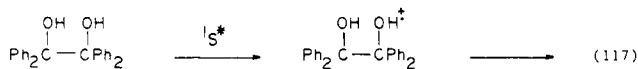

The photosensitized [4 + 4] cycloreversion of the anthracene dimer has also been demonstrated to proceed via electron transfer:³³⁴

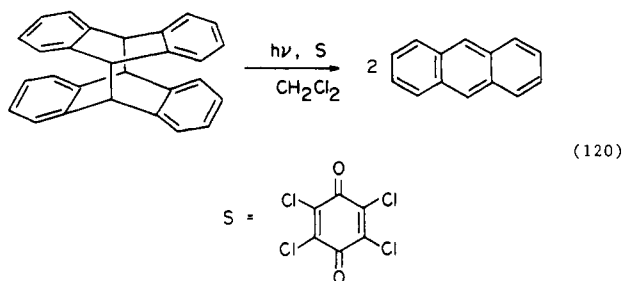

Singlet and triplet energy transfer is excluded because both processes are endothermic. The observation of CIDNP signals from the dimer and the anthracene product has been analyzed in terms of formation of radical cation dimers followed by bond cleavage.

3. Valence Isomerizations

The rearrangement of norbornadiene to the more energy-rich quadricyclane and the reverse reaction can take place on photolysis in polar solvents in the presence of electron-deficient photosensitizers.³³⁵⁻³³⁸



Under these conditions, the rearrangement is marked by distinctive features which suggest that radical cations of the substrates are the key intermediates. Electron transfer from either valence isomer to the excited states of electron-deficient sensitizers is supported by thermodynamic considerations. For example, in the presence of triplet chloranil or singlet 1-cyanonaphthalene, electron transfer is exothermic (Table XXI).^{335,336} Norbornadiene and quadricyclane both quench the fluorescence of 1-cyanonaphthalene and undergo isomerization. The isomerization of quadricyclane is more efficient. Triplet chloranil can also induce the isomerization of quadricyclane.

In the presence of both singlet and triplet sensitizers, the ring-opening of quadricyclane displays a significant solvent dependence.³³⁷ For example, the efficiency of ring-opening on sensitization by singlet 1-cyanonaphthalene is reduced dramatically with increasing polarity of the solvent. This observation suggests that reversible electron transfer is an important pathway in polar solvents and substantially diminishes the yield of isomerization.³³⁸

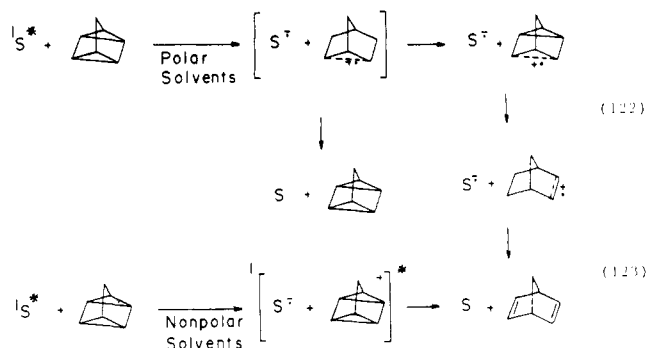

Flash photolysis studies also support the importance of reversible electron transfer in these reactions. For example, transient radical ions generated by singlet sensitizers are not normally observed in polar solvents such as acetonitrile. However, sensitization with triplet chloranil results in transient chloranil radical anions which can be detected by flash spectroscopy. As pointed out Section II.D, "in-cage" triplet radical ion pairs tend to diffuse apart more readily than singlet ions.

Valence isomerizations are striking examples of the power of CIDNP to sort out the dynamics of electron transfer. The results of photo-CIDNP experiments are compatible with competition between reversible electron transfer and intersystems crossing, which occur within a solvent cage, and separation from the solvent cage. The latter process is accompanied by slow nuclear spin relaxation, which reduces polarization signals.

The polarization patterns detected in valence isomerizations reflect hyperfine-induced intersystem crossing between singlet and triplet radical ion pairs (Figures 17 and 18). There are several interesting conclusions to be drawn from these patterns. First, the CIDNP spectra suggest that two types of radical ion intermediates are involved. For example, in the presence of triplet chloranil, norbornadiene does not isomerize to quadricyclane, yet its NMR shows enhanced absorption and weak emission. This observation suggests a barrier to isomerization for the norbornadiene radical cation. Reversible electron transfer to its polarized ground state is an important pathway. In contrast, the chloranil-sensitized isomerization of quadricyclane is more efficient and leads to polarization of both isomers. It has been postulated that these observations reflect different reactivity patterns for the radical cations derived from either isomer (Figure 19).³³⁶ The radical cation of quadricyclane is more reactive, and its isomerization proceeds downhill on the energy surface. Photoelectron spectra and MINDO/3 calculations support the existence of two structurally distinct radical cations.³³⁶

Another important point is the demonstration of triplet recombination when high-energy sensitizers are employed. In section II.D, the possibility of populating low-lying triplet states by triplet recombination was discussed (Figure 14). Triplet recombination in the 1-cyanonaphthalene-sensitized isomerization of norbornadiene and quadricyclane is confirmed by photo-CIDNP patterns. In particular, the triplet states of the isomers, which can be generated by triplet recombination, proceed preferentially to quadricyclane. This conclusion is supported by the observation that the isomerization can be sensitized by triplet sensitizers (via energy transfer) on an energy surface whose topology

TABLE XXI. Thermodynamic Parameters and Quantum Efficiencies of Selected Valence Isomerizations^a

sensitizer	E_T , kcal/mol	valence isomer	E_T , kcal/mol	ΔG , kcal/mol ^b	ϕ_i^c	ref
¹ 1-cyanonaphthalene*	57.4	norbornadiene	~70	-8.3	~0.01	335
¹ 1-cyanonaphthalene*	57.4	quadriclyane	~80	-22.8	~0.1	337
³ chloranil*	62.3	norbornadiene	~70	-27.2	0.00	336
³ chloranil*	62.3	quadriclyane	~80	-41.7	~0.6	335
¹ phenanthrene*	62.0	dimethylbicyclo[2.2.1]hepta-2,5-diene-2,3-dicarboxylate	50	-7.8	~0.2	341
¹ pyrene*	48.0	dimethylbicyclo[2.2.1]hepta-2,5-diene-2,3-dicarboxylate	53	-10.8	<0.005	341

^aIn CD₃CN. ^b ΔG for electron transfer calculated from eq 17. ^cIsomerization quantum yield.

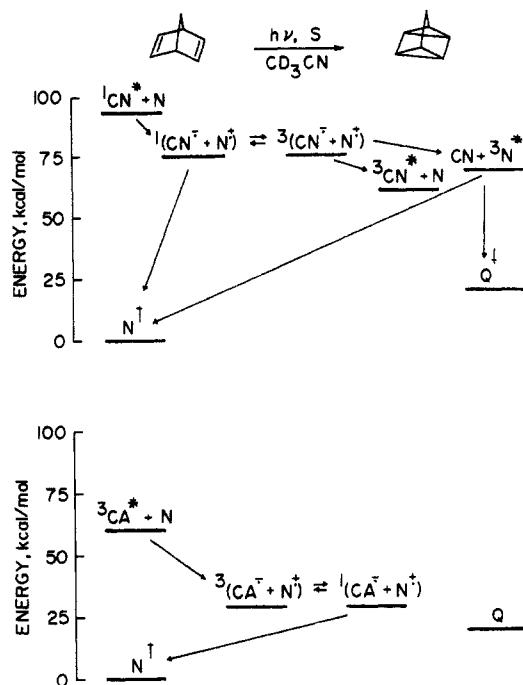

Figure 17. Energetics of the rearrangement of norbornadiene (N) sensitized by 1-cyanonaphthalene (CN) and chloranil (CA). Superscript "daggers" represent polarization.

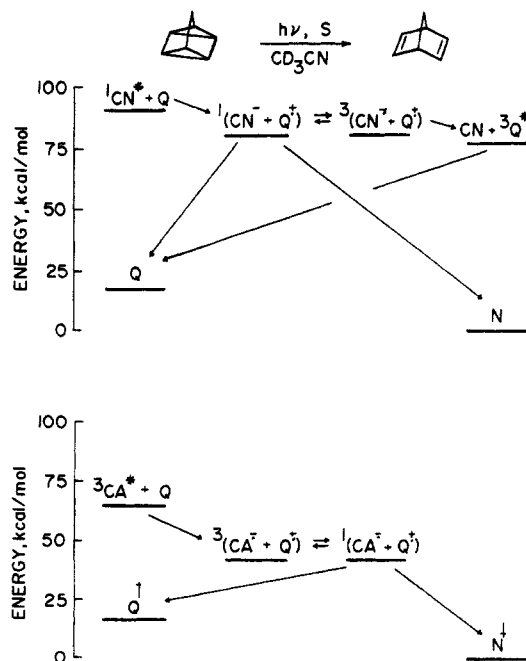

Figure 18. Energetics of the rearrangement of quadriclyane (Q) sensitized by 1-cyanonaphthalene (CN) and chloranil (CA). Superscript "daggers" represent polarization.

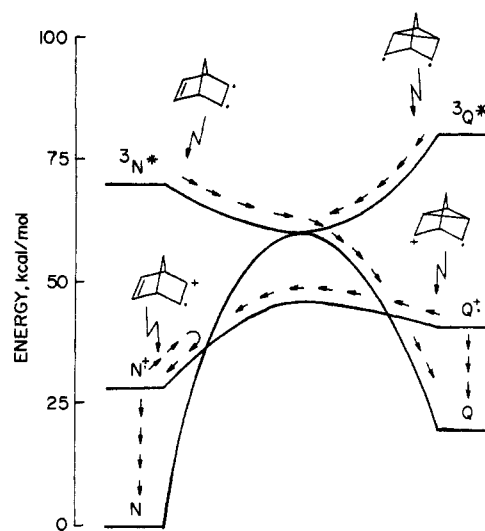

Figure 19. Comparison of the energy surfaces of the norbornadiene-quadriclyane valence isomerization. The reaction may proceed via diradicaloid intermediates (as in energy transfer) or via radical cation intermediates (as in electron transfer). In this example, the radical cations are presumed to be generated by sensitization with chloranil.

clearly favors formation of quadriclyane (Figure 19).³³⁹ (The triplet-sensitized isomerization proceeds by diradicaloid intermediates.) This example is a vivid demonstration of the different reactivity patterns for reactions sensitized by electron and energy transfer.

The involvement of ionic and excited-state intermediates in the 1-cyanonaphthalene-sensitized isomerization of quadriclyane is fully consistent with the notable lack of polarization in quadriclyane. Because quadriclyane can be regenerated by reversible electron transfer from singlet radical ion pairs or by decay from its triplet state, the opposite polarization of signals resulting from singlet and triplet intermediates might tend to more or less cancel each other.³³⁶

A particularly noteworthy aspect of these studies is the remarkable similarity of triplet recombination to energy transfer by electron exchange. We already raised the possibility that triplet recombination is actually a stepwise electron exchange (section II.D). The 1-cyanonaphthalene-sensitized isomerization of either valence isomer is an example of spin-forbidden singlet-triplet energy transfer, although the details clearly involve consecutive electron transfer.

Triplet recombination has also been postulated to explain the CIDNP patterns observed in the sensitized isomerization of dimethylbicyclo[2.2.1]hepta-2,5-diene-2,3-dicarboxylate (Figure 20).³⁴⁰⁻³⁴² This molecule is a potent electron acceptor which in polar solvents quenches the fluorescence of the singlet states of aro-

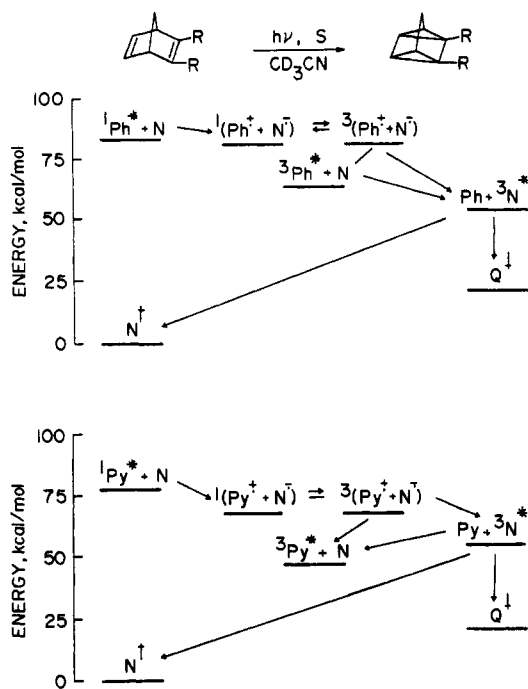
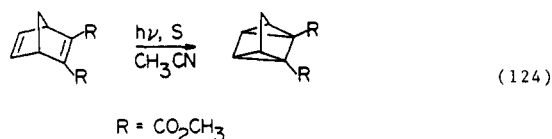

Figure 20. Energetics of the rearrangement of dimethyl bicyclo[2.2.1]hepta-2,5-diene-2,3-dicarboxylate sensitized by phenanthrene (Ph) and pyrene (Py). R = CO₂CH₃. Superscript "daggers" represent polarization.

matic electron donors at diffusion-controlled rates. Under these conditions, this substrate undergoes isomerization:



A novel feature of this reaction is the variation in isomerization yield with triplet energy of the sensitizer (Table XXI). Thus, triphenylene and phenanthrene are more effective as sensitizers. With phenanthrene, strong photo-CIDNP signals are observed, and the phenanthrene radical cation can be readily detected by flash photolysis. Weak CIDNP signals are observed for pyrene. These results are consistent with triplet recombination pathways (Figure 20). Singlet sensitizers with triplet energies in excess of 53 kcal/mol, e.g., phenanthrene, generate geminate singlet radical ion pairs in the primary step, followed by spin inversion to triplet pairs and triplet recombination. The observed polarization of the quadracycane product is explicable in terms of a rearrangement involving the triplet state of the acceptor because of the relative high barrier to isomerization noted for olefinic radical anions. The low efficiency of the pyrene-sensitized isomerization has been attributed to population of the low-lying triplet state of pyrene which "short-circuits" the pathway for isomerization.

Examples of sensitized valence isomerizations of other organic ring systems have been recorded. A particularly interesting reaction is the isomerization of hexamethyl (Dewar) benzene in the presence of singlet sensitizers.^{343,344}

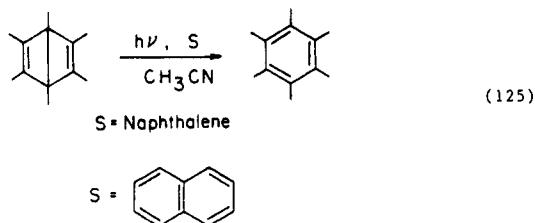

The isomerization proceeds by chain propagation because of the very high quantum yield of product formation measured for this reaction:

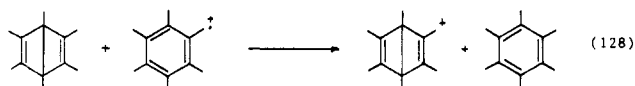
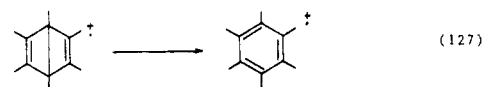
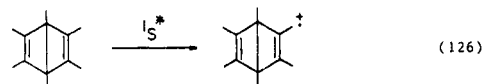

4. Photooxygenations

Photooxygenations have long been considered to proceed via energy-transfer quenching, involving sensitization of oxygen by the sensitizer triplet to form excited singlet oxygen—the reactive intermediate (section IV.B.1.e). This mechanism was established in the 1960s and has explained the majority of photooxygenations which were known at that time. However, several reactions could not be explained by this mechanism. Recent studies clearly support an electron transfer in such cases.^{124,345-353}

A typical example involves the oxygenation of electron-rich olefins conjugated to aromatic moieties, with electron-deficient sensitizers (e.g., 9,10-dicyanoanthracene):^{149,345}

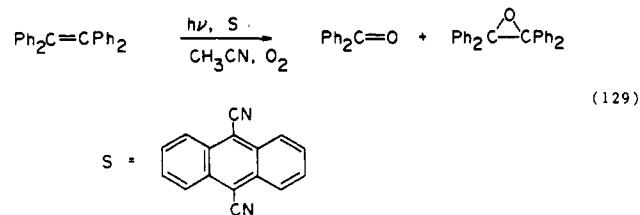

This reaction occurs with a variety of olefins (e.g., stilbene derivatives,¹⁴⁹ indene,³⁴⁹ and 1-diphenylethylene,^{149,345} aromatic-substituted acetylenes,³⁴⁷ and diphenyl sulfide.³⁴⁵

Several aspects of these reactions are inconsistent with an energy-transfer pathway involving singlet oxygen. The reactions take place in polar solvents, not quenched by typical singlet oxygen quenchers, and do not take place in the presence of typical singlet oxygen sensitizers (rose bengal, methylene blue, etc.).^{149,345}

The singlet-state of electron-deficient sensitizers are quenched at diffusion-controlled rates in the presence of oxygen, thereby preventing an energy-transfer mechanism, since the latter must occur from the sen-

sensitizer triplet.^{149,345} The rate constants for product formation are identical with the rate constants for fluorescence quenching. This result supports a reaction involving the sensitizer singlet. The mechanism which appears to be most consistent with these observations is shown below:

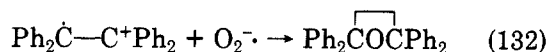
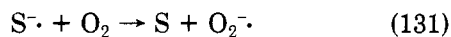
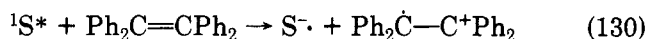

The excited state of the sensitizer is quenched by the substrate to produce the sensitizer anion radical and olefin cation radical. The reduced sensitizer donates an electron to ground-state oxygen to generate superoxide ($\text{O}_2^{\cdot-}$), which subsequently reacts with the olefin cation radical to form products. This mechanism parallels the reactions of electron-rich olefins which were examined in section IV.C.1.

Support for this mechanism has been provided by most of the techniques described in Section III.^{149,345,350} First, as already mentioned, these reactions occur only in polar solvents, thus supporting the formation of charged intermediates which subsequently separate and undergo reactions. Second, energetics, as determined from the Weller equation (eq 16), are consistent with electron transfer. The formation of $\text{O}_2^{\cdot-}$ is exothermic, as calculated from the redox potentials of the sensitizer and O_2 (Table XI). Thus, ΔG for reaction 131 is calculated to be -0.7 kcal/mol. Third, these reactions can be quenched in the presence of donors of low oxidation potentials. Electron acceptors, e.g., benzoquinone, also quench these reactions by accepting an electron from the radical anion of the sensitizer or superoxide.³⁵⁴

Various transient intermediates have been detected and identified, e.g., the radical anion of 1,4-dicyanophthalene by ESR¹²⁴ and laser transient absorption,³⁴⁶ and the *trans*-stilbene cation radical by laser transient absorption.³⁴⁶

Product studies support the proposed pathway. For example, solutions of dimethylindene irradiated in the presence of tetracyanoanthracene and oxygen were shown to give clean mixtures of hydroperoxides:³⁴⁹

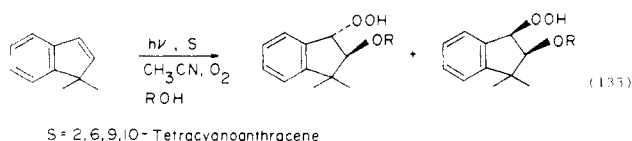

The steps involve formation of the dimethylindene radical cation, nucleophilic addition of an alcohol to the cation, addition of ground-state oxygen, reverse electron transfer from the sensitizer radical anion, and finally protonation to give products:

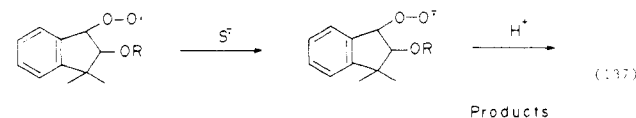
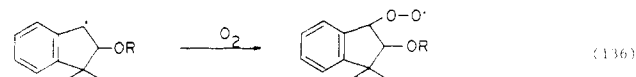
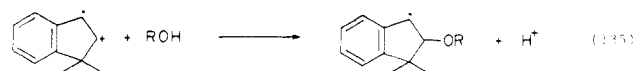
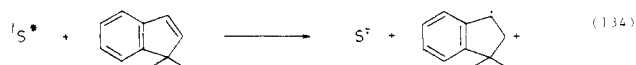

With methylene blue (MB), a known singlet oxygen sensitizer, employed, a decidedly different mixture is obtained:

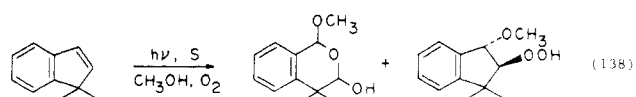

The initial step in the singlet oxygen reaction requires addition of singlet oxygen to the olefin:

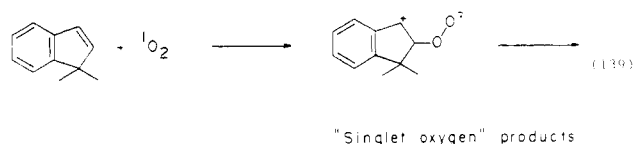

An electron-transfer mechanism has been proposed for the photooxygenation of *trans*-stilbene in the presence of dicyanoanthracene:¹⁴⁹

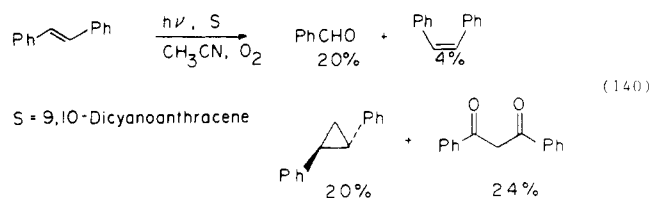

Energy transfer is unlikely, since *trans*-*cis* isomerization does not occur in nitrogen-purged solutions.

The 9,10-dicyanoanthracene-sensitized photooxygenation of diphenyl-2-methoxyethylene has been shown to give an endoperoxide product and benzophenone:³⁵⁰

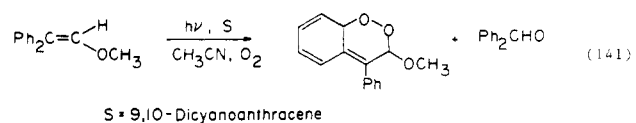

The endoperoxide is formed by [2 + 4] singlet oxygen addition. Benzophenone, however, can apparently be formed by both singlet oxygen and electron-transfer pathways. In the presence of *trans*-stilbene, the ratio of benzophenone increases substantially, presumably through a pathway involving oxidation of the electron-rich olefin:

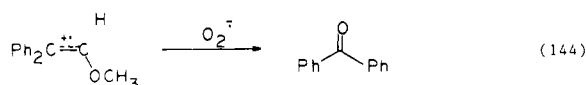
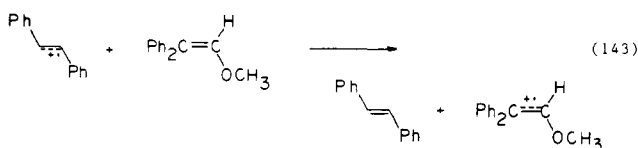
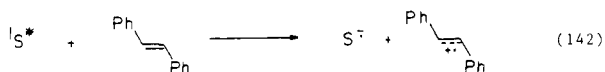

In this example, *trans*-stilbene functions as a cosensitizer.

A similar example of cosensitization has been observed in the reaction of tetraphenylcyclopropane:³⁵¹⁻³⁵³

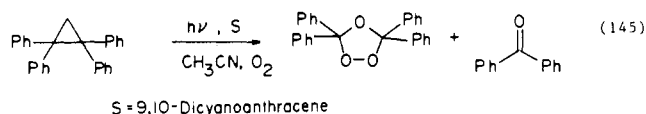

The hydroperoxide product is formed by a mechanism analogous to the cosensitization pathway in Scheme II. The overall reaction, however, proceeds slowly. Photolysis of solutions of rose bengal and tetraphenylcyclopropane does not result in product formation. Thus singlet oxygen is not involved. Addition of biphenyl, however, greatly enhances the rate of product formation:

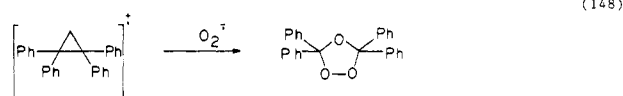
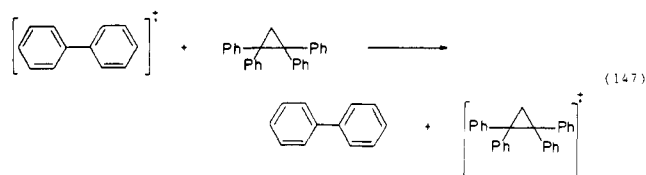
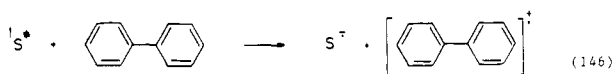

Although electron transfer from tetraphenylcyclopropane to the biphenyl cation is thermodynamically unfavorable, the accompanying reactions, i.e., ring-opening and addition of O₂, provide the driving force. This example illustrates how a cosensitizer can be of practical utility in enhancing product yield.³⁵³

Although we have emphasized the formation of superoxide via sensitization with electron-deficient molecules, mention should be made of alternate methods. In section IV.B.1, it was stated that sensitization by triplet porphyrins can result in O₂ directly by electron donation to ground-state O₂. O₂ can also be generated by electron transfer from amine donor molecules to singlet oxygen, as deduced by steady-state and flash photolysis studies.³⁵⁵

V. Prospects

One objective in preparing this review was to present a fusion of several trends of thought and research currently pursued in the area of photosensitized elec-

tron transfer. We have sought to emphasize the role of energetics, kinetic barriers, and solution dynamics. We hasten to add the caveat that, although many experimental investigations continue to rely on simple thermodynamic arguments to substantiate the concept of electron transfer (as indeed they should!), it is clear that more attention must be paid to experimental techniques used to verify the electron-transfer pathway.

As we have shown, a detailed characterization of electron-transfer processes involving excited states has yet to be formulated. Still, using examples from organic and inorganic photochemistry, we have attempted to show that the classical theory of Marcus provides a powerful formalism for examining the effects of structure and environment. Much remains to improve on our understanding of the nuclear barriers involving organic substrates. Although many investigations are now emphasizing the importance of "solvent-assisted" photosensitized electron transfer, the role of bond length changes remains unclear. Work is now proceeding to understand the structural differences between various amine cations.³⁵⁶ We that predict these studies will be extended to photochemical studies.

Temperature studies should be useful in sorting out nuclear and electron barriers, as was pointed out in a recent review.²³ These investigations should also be useful in improving on our understanding of "entropy-driven" electron transfer, a subject which deserves further attention. In fact, an example of entropy-driven exciplex formation was recently reported.³⁵⁷

Another area where we can predict continued investigation will involve studies of systems where competitive electron and energy transfer take place. We have hinted at the conceptual similarities of electron transfer and energy transfer by electron exchange. Energetics are important, but in cases where both pathways are exothermic, we have suggested that kinetic barriers of both pathways can influence the quenching pathway. As more sensitive and sophisticated techniques for monitoring excited states and charge-transfer intermediates are exploited (e.g., time-resolved laser flash spectroscopy coupled with resonance Raman, electron-spin resonance, chemically induced nuclear polarization, chemically induced electron polarization,³⁵⁸ etc.), we can expect to learn more about the nature of the complex intermediates and pathways in electron transfer and exchange.

As we showed in section IV.B.3, and electron can travel over relatively large distances, exceeding 10 Å in intramolecular systems. Studies of photoinduced electron transfer in these systems will undoubtedly continue. One of the remaining major questions involves the nature of nuclear and electronic barriers in intramolecular electron transfer. If nuclear organization is important, can the rate of electron transfer be made to slow down by "freezing" nuclear motion? Also, little is known about the effects of mutual orientation of the donor and acceptor on electronic coupling. Answers to these questions will be useful in unraveling the complexities of electron transfer in biological systems.²³ Future work will most certainly involve reactions in micelles and other microheterogeneous systems^{359,360} and in novel intramolecular donor-acceptor pairs.³⁶¹ Already there is flourishing activity on the effects of distance in membranes and proteins using photochemical means of generating excited states.³⁶² Studies on

these systems will help to unravel the complexities of the effects of electrostatic control of electron transfer.⁸⁴

The utilization of currently available techniques to support photochemical electron transfer was surveyed with attention to selected reactions. These examples are only suggestive of the enormous potential which photosensitized electron transfer will have in the hands of the organic chemist. The search for novel photosensitizers should greatly help in this effort.³⁶³ The application of these sensitizers to synthetic organic chemistry is another area of great potential.³⁶⁴

In conclusion, we can predict that a sustained effort to study photosensitized electron transfer in novel and unconventional systems promises to help solve the complex issues raised in this article.

VI. Acknowledgments

N.J.T. thanks Professor R. A. Marcus for his interest and stimulating discussions. He also expresses his fondest gratitude to Professor Harry Gray and his research group for providing a stimulating tutorial on inorganic photochemistry and electron transfer during N.J.T.'s tenure as a Sherman Fairchild Fellow at Caltech. G.J.K. gratefully acknowledges the helpful comments and encouragement of Professor Bruno Vittimberga. We both acknowledge the assistance of Dr. Sidney Cox on sections III and IV.C.4 and the critical and meticulous reading of this manuscript provided by Dr. Ken Waterman. We thank the National Science Foundation and Air Force Office of Scientific Research for their generous support of this project.

VII. References

- (1) Turro, N. J. "Modern Molecular Photochemistry"; Benjamin/Cummings: Menlo Park, CA, 1978; Chapter 9.
- (2) Dexter, D. L. *J. Chem. Phys.* **1953**, *21*, 836.
- (3) Forster, T. *Faraday Discuss. Chem. Soc.* **1959**, *27*, 7.
- (4) Turro, N. J.; Dalton, J. C.; Weiss, D. S. "Organic Photochemistry"; Chapman, O. L., Ed.; Marcel Dekker: New York, 1969; Vol. 2, p 1.
- (5) Stryer, L.; Haugland, R. P. *Proc. Natl. Acad. Sci. U.S.A.* **1967**, *58*, 719.
- (6) Lamola, A. A. "Energy Transfer and Organic Photochemistry"; Interscience: New York, 1969.
- (7) Turro, N. J. *Pure Appl. Chem.* **1977**, *49*, 405.
- (8) Leonhardt, H.; Weller, A. *Ber. Bunsenges. Phys. Chem.* **1963**, *67*, 791.
- (9) Forster, T. In "The Exciplex"; Gordon, M. A., Ware, W. R., Eds.; Academic: New York, 1975, p 1.
- (10) Mataga, N.; Mitiga, M.; Nishimura, T. *J. Mol. Struct.* **1978**, *47*, 199.
- (11) Roth, H. D. In "Chemically Induced Magnetic Polarization"; Muus, L. T., et al., Eds.; D. Reidel: Dordrecht, Holland, 1977; pp 39-76.
- (12) Taube, H. "Electron Transfer Reactions of Complex Ions in Solutions"; Academic: New York, 1970.
- (13) Taube, H. *Angew. Chem.* **1984**, *23*, 329.
- (14) Libby, W. F. *Annu. Rev. Phys. Chem.* **1977**, *28*, 105.
- (15) Marcus, R. A. *Annu. Rev. Phys. Chem.* **1964**, *15*, 155.
- (16) Hush, N. S. In "Mechanistic Aspects of Inorganic Reactions"; ACS Symposium Series 198; Rorabacker, D. B., Endicott, J. F., Eds.; American Chemical Society: Washington, DC, 1982; Chapter 13.
- (17) Sutin, N. In "Bioinorganic Chemistry", Eichorn, G. L., Ed.; American Elsevier: New York, 1973; Vol. 2, Chapter 19.
- (18) Balzani, V.; Bolletta, F.; Gandolfi, M. T.; Maestri, M. *Top. Curr. Chem.* **1978**, *75*, 1.
- (19) Julliard, M.; Chanon, M. *Chem. Rev.* **1983**, *83*, 425.
- (20) Chibisov, K. *Russ. Chem. Rev. (Engl. Transl.)* **1981**, *50*, 1169.
- (21) Mauzerall, D.; Ballard, S. G. *Annu. Rev. Phys. Chem.* **1982**, *33*, 377.
- (22) Beecroft, R. A.; Davidson, R. S.; Goodwin, D.; Pratt, J. E. *Pure Appl. Chem.* **1982**, *54*, 1605.
- (23) Marcus, R. A.; Sutin, N. *Biochim. Biophys. Acta* **1985**, *811*, 265.
- (24) Albini, A. *Synthesis* **1981**, 249.
- (25) Mattes, S. L.; Farid, S. In "Organic Photochemistry"; Padwa, A., Ed.; Marcel Dekker: New York, 1983; Vol. 6, p 233.
- (26) Sutin, N. *J. Photochem.* **1979**, *10*, 19.
- (27) Whitten, D. G. *Acc. Chem. Res.* **1980**, *13*, 83.
- (28) Gratzel, M. *Ber. Bunsenges. Phys. Chem.* **1980**, *84*, 981.
- (29) Balzani, V.; Scandola, F. In "Photochemical Conversion and Storage of Solar Energy"; Connolly, J. S., Ed.; Academic: New York, 1981; Chapter 4.
- (30) Maverick, A. W.; Gray, H. B. *Pure Appl. Chem.* **1980**, *52*, 2339.
- (31) Moore, J. W.; Pearson, R. G. "Kinetics and Mechanism"; Wiley: New York, 1981; p 237.
- (32) Sutin, N. *Acc. Chem. Res.* **1982**, *15*, 275.
- (33) Cannon, R. D. "Electron Transfer Reactions"; Butterworths: London, 1980; p 97.
- (34) Beens, H.; Knibbe, H.; Weller, A. *J. Chem. Phys.* **1967**, *47*, 1183.
- (35) Baumann, W.; Bischof, H.; Frohling, J. C. *J. Lumin.* **1981**, *24/25*, 555.
- (36) Ottolenghi, M. *Acc. Chem. Res.* **1973**, *6*, 153.
- (37) Reference 1, pp 354-355.
- (38) Reference 33, pp 300-301.
- (39) Chu, S. Y.; Lee, T. S. *Nouv. J. Chim.* **1982**, *6*, 155.
- (40) Kuznetsov, A. M.; Ulstrup, J. *Chem. Phys. Lett.* **1983**, *97*, 285.
- (41) Weller, A. *Pure Appl. Chem.* **1968**, *16*, 115.
- (42) Rehm, D.; Weller, A. *Isr. J. Chem.* **1970**, *8*, 259.
- (43) Weller, A. In "The Exciplex"; Gordon, M. A.; Ware, W. R., Eds.; Academic: London, 1975; pp 23-36.
- (44) Weller, A. *Z. Phys. Chem.* **1982**, *133*, 93.
- (45) Masuhara, H.; Mataga, N. *Acc. Chem. Res.* **1981**, *14*, 312.
- (46) Mataga, N. *Pure Appl. Chem.* **1984**, *56*, 1255.
- (47) Mataga, N. In "The Exciplex"; Gordon, M. A., Ware, W. R., Eds.; Academic: London, 1975; pp 113-140.
- (48) Marcus, R. A. *J. Chem. Phys.* **1956**, *24*, 966.
- (49) Marcus, R. A. *J. Chem. Phys.* **1956**, *24*, 979.
- (50) Marcus, R. A. *J. Chem. Phys.* **1957**, *26*, 867.
- (51) Marcus, R. A. *J. Chem. Soc.* **1957**, *26*, 872.
- (52) Marcus, R. A. *Faraday Discuss. Chem. Soc.* **1960**, *29*, 21.
- (53) Marcus, R. A. *J. Chem. Phys.* **1965**, *43*, 679.
- (54) Hush, N. S. *J. Chem. Phys.* **1958**, *28*, 962.
- (55) Reference 1, pp 247-248.
- (56) Jones, G., II; Butler, R. J. *Sol. Energy* **1982**, *29*, 579.
- (57) Marcus, R. A. *Int. J. Chem. Kinet.* **1981**, *13*, 865.
- (58) Perrin, F. C. R. *Hebd. Seances Acad. Sci.* **1924**, *178*, 1978.
- (59) Reference 1, pp 317-318.
- (60) Guarr, T.; McGuire, M.; Strauch, S.; McLendon, G. *J. Am. Chem. Soc.* **1983**, *103*, 606.
- (61) Libby, W. F. *J. Phys. Chem.* **1952**, *56*, 863.
- (62) Libby, W. F. *J. Chem. Phys.* **1963**, *38*, 420.
- (63) Salem, L. "Electrons in Chemical Reactions"; Wiley: New York, 1982; Chapter 5.
- (64) Fukui, K. *Acc. Chem. Res.* **1971**, *4*, 57.
- (65) Reference 1, p 201.
- (66) Hopfield, J. J. *Proc. Natl. Acad. Sci. U.S.A.* **1974**, *77*, 3690.
- (67) Zamaraev, K. I.; Khairutdinov, R. F. *Russ. Chem. Rev. (Engl. Transl.)* **1978**, *47*, 518.
- (68) Newton, M.; Sutin, N. *Annu. Rev. Phys. Chem.* **1984**, *35*, 437.
- (69) Pearson, R. G. *Acc. Chem. Res.* **1971**, *4*, 152.
- (70) Brocklehurst, B. *J. Phys. Chem.* **1979**, *83*, 536.
- (71) Reference 1, p 224.
- (72) Dauben, W. G.; Salem, L.; Turro, N. J. *Acc. Chem. Res.* **1975**, *8*, 41.
- (73) Siders, P.; Cave, R. J.; Marcus, R. A. *J. Chem. Phys.* **1984**, *81*, 5613.
- (74) Stevens, B. *J. Phys. Chem.* **1984**, *88*, 702.
- (75) Yekta, A.; Turro, N. J. *Chem. Phys. Lett.* **1972**, *17*, 31.
- (76) Brunshwig, B. S.; Logan, J.; Newton, M. D.; Sutin, N. *J. Am. Chem. Soc.* **1980**, *102*, 5798.
- (77) Sutin, N.; Brunshwig, B. S. In "Mechanistic Aspects of Inorganic Reactions"; ACS Symposium Series 198; Rorabacker, D. R.; Endicott, J. F., Eds.; American Chemical Society: Washington, DC; Chapter 5.
- (78) Endicott, J. F.; Kumar, K.; Ramasami, J.; Rotzinger, F. P. *Prog. Inorg. Chem.* **1983**, *30*, 141.
- (79) Ebersson, L. *Adv. Phys. Org. Chem.* **1982**, *18*, 79.
- (80) Warshel, A. *Proc. Natl. Acad. Sci. U.S.A.* **1980**, *77*, 3105.
- (81) Warshel, A. *Acc. Chem. Res.* **1981**, *14*, 284.
- (82) Warshel, A. *J. Phys. Chem.* **1982**, *86*, 2218.
- (83) Grampp, G.; Jaenicke, W. *Ber. Bunsenges. Phys. Chem.* **1984**, *88*, 325.
- (84) Grampp, G.; Jaenicke, W. *Ber. Bunsenges. Phys. Chem.* **1984**, *88*, 335.
- (85) Marcus, R. A. *J. Phys. Chem.* **1963**, *67*, 853.
- (86) Brunshwig, B.; Sutin, N. *J. Am. Chem. Soc.* **1978**, *100*, 7568.
- (87) Reference 33, pp 205-207.
- (88) Speiser, S. *J. Photochem.* **1983**, *22*, 195.
- (89) Balzani, V.; Bolletta, F.; Scandola, F. *J. Am. Chem. Soc.* **1980**, *102*, 2152.
- (90) Ermolaev, V. L. *Sov. Phys.—Dokl. (Engl. Transl.)* **1967**, *6*, 600.

- (91) Reference 1, p 40.
- (92) Kestner, N. R.; Logan, J.; Jortner, J. *J. Phys. Chem.* **1974**, *78*, 2148.
- (93) Marcus, R. A.; Siders, P. *J. Phys. Chem.* **1982**, *86*, 622.
- (94) Miller, J. R.; Calcaterra, L. T.; Closs, G. L. *J. Am. Chem. Soc.* **1984**, *106*, 3047.
- (95) Engel, R. S.; Steel, C. *Acc. Chem. Res.* **1973**, *6*, 275.
- (96) Marcus, R. A.; Sutin, N. *Inorg. Chem.* **1975**, *14*, 213.
- (97) Taube, H. *J. Am. Chem. Soc.* **1955**, *77*, 4481.
- (98) Zwicker, A. M.; Taube, H. *J. Am. Chem. Soc.* **1959**, *81*, 2915.
- (99) Weller, A. *Pure Appl. Chem.* **1982**, *54*, 1885.
- (100) Nolting, F.; Staerk, H.; Weller, A. *Chem. Phys. Lett.* **1982**, *88*, 523.
- (101) Turro, N. *Proc. Natl. Acad. Sci. U.S.A.* **1983**, *80*, 609.
- (102) Calvert, J. G.; Pitts, J. N. "Photochemistry"; Wiley: New York, 1966; Chapter 6.
- (103) Bard, A. J.; Faulkner, L. R. "Electrochemical Methods"; Wiley: New York, 1980.
- (104) Murov, S. L. "Handbook of Photochemistry"; Marcel Dekker: New York, 1973.
- (105) Birks, J. B. "Photophysics of Aromatic Molecules"; Wiley: London, 1970.
- (106) Bock, C. R.; Connor, J. A.; Gutierrez, A. R.; Meyer, T. J.; Whitten, D. G.; Sullivan, B. P.; Nagle, J. K. *J. Am. Chem. Soc.* **1979**, *101*, 4815.
- (107) Maharaj, U.; Winnik, M. A. *Tetrahedron Lett.* **1982**, *23*, 3035.
- (108) Gassman, P. G.; Olson, K. D.; Walter, L.; Yamaguchi, R. *J. Am. Chem. Soc.* **1981**, *103*, 4977.
- (109) Baggott, J. E.; Pilling, M. J. *J. Chem. Soc., Faraday Trans. 1* **1983**, *79*, 221.
- (110) Porter, G. In "Techniques of Organic Chemistry", 2nd ed.; Friess, S. L., Lewis, E. S., Weissberger, A., Eds.; Wiley-Interscience: New York, 1963; Vol. 8, part 2.
- (111) Rabek, J. F. "Experimental Methods in Photochemistry and Photophysics"; Wiley-Interscience: New York, 1982; Part 2 Chapter 23.
- (112) Porter, G.; West, M. A. In "Techniques in Chemistry, Investigation of Rates and Mechanisms of Reactions"; Weissberger, A., Hawkins, G. G., Eds.; Wiley-Interscience: New York, 1973; p 2.
- (113) Habersbergerova, A.; Janovsky, I.; Kourim, P. *Radiat. Res. Rev.* **1972**, *4*, 123.
- (114) Aruga, T.; Ito, O.; Mutsuda, M. *J. Phys. Chem.* **1982**, *80*, 2950.
- (115) Hilinski, E. F.; Rentzepis, P. M. *Acc. Chem. Res.* **1983**, *16*, 224.
- (116) Forster, M.; Hester, R. E. *Chem. Phys. Lett.* **1982**, *85*, 287.
- (117) Jarnigan, R. C. *Acc. Chem. Res.* **1971**, *4*, 420.
- (118) Hino, T.; Akazawa, H.; Mashara, H.; Mataga, N. *J. Phys. Chem.* **1976**, *80*, 33.
- (119) Shizuka, H.; Obuchi, H. *J. Phys. Chem.* **1982**, *86*, 1297.
- (120) Davidson, R. S.; Lamberth, P. F.; Santhanam, M. *J. Chem. Soc., Perkin Trans. 2* **1972**, 2351.
- (121) Schomberg, H.; Staerk, H.; Weller, A. *Chem. Phys. Lett.* **1973**, *22*, 1.
- (122) Grellman, K. H.; Watkins, A. R.; Weller, A. *J. Phys. Chem.* **1972**, *76*, 469.
- (123) Orbach, N.; Potashnik, R.; Ottolenghi, M. *J. Phys. Chem.* **1972**, *76*, 1133.
- (124) Schaap, A. P.; Zaklika, K. A.; Kaskar, B.; Fung, L. V.-M. *J. Am. Chem. Soc.* **1980**, *102*, 389.
- (125) Sostero, S.; Traverso, O.; Bernardo, F. D.; Kemp, T. J. *J. Chem. Soc., Dalton Trans.* **1979**, 659.
- (126) Zubarev, V. E.; Belevskii, V. N.; Bugaenko, L. T. *Russ. Chem. Rev. (Engl. Transl.)* **1979**, *48*, 1361.
- (127) Noda, S.; Doba, T.; Mizuda, T.; Miura, M.; Yoshida, H. *J. Chem. Soc., Perkin Trans. 2* **1980**, 61.
- (128) Hore, P. J.; Joslin, C. G.; McLauchlan, K. A. *Chem. Soc. Rev.* **1979**, *8*, 29.
- (129) Hore, P. J.; McLauchlan, K. A. *Chem. Phys. Lett.* **1980**, *75*, 582.
- (130) Glarum, S. H. In "Chemically Induced Magnetic Polarization"; Lepley, A. R., Closs, G. L., Eds.; Wiley-Interscience: New York, 1973; Chapter 1.
- (131) Kaptein, R. *Adv. Free-Radical Chem.* **1975**, *5*, 319.
- (132) Roth, H. D.; Schilling, M. L. M. *J. Am. Chem. Soc.* **1980**, *102*, 4303.
- (133) Closs, G. L.; Czeropski, M. S. *J. Am. Chem. Soc.* **1977**, *99*, 6126.
- (134) Turro, N. J. *J. Photochem.* **1984**, *25*, 69.
- (135) Reference 1, Chapter 5.
- (136) Weller, A.; Zachariasse, K. *J. Chem. Phys.* **1967**, *46*, 4984.
- (137) Jones, G., II; Schwarz, W.; Malba, B. *J. Phys. Chem.* **1982**, *86*, 22.
- (138) Gassman, P. G.; Olson, K. D. *J. Am. Chem. Soc.* **1982**, *104*, 3740.
- (139) Maroulis, A. J.; Shigemitsu, Y.; Arnold, D. R. *J. Am. Chem. Soc.* **1978**, *100*, 535.
- (140) Arnold, D. R.; Maroulis, A. J. *J. Am. Chem. Soc.* **1976**, *98*, 5931.
- (141) Maroulis, A. J.; Arnold, D. R. *Synthesis* **1979**, 819.
- (142) Mattes, S. L.; Farid, S. *J. Am. Chem. Soc.* **1982**, *104*, 1454.
- (143) Schaap, A. P.; Siddiqui, S.; Gagnon, S. D.; Lopez, L. *J. Am. Chem. Soc.* **1983**, *105*, 5149.
- (144) Majima, J.; Pac, C.; Nakasone, A.; Sakurai, H. *J. Am. Chem. Soc.* **1981**, *103*, 4499.
- (145) Brown-Wensley, K.; Mattes, S. L.; Farid, S. *J. Am. Chem. Soc.* **1978**, *100*, 4162.
- (146) Davidson, R. S.; Goodwin, D. *J. Chem. Soc., Perkin Trans. 2* **1982**, 1559.
- (147) Schulten, K.; Weller, A. *Biophys. J.* **1978**, *24*, 295.
- (148) Weller, A.; Nolting, F.; Staerk, H. *Chem. Phys. Lett.* **1983**, *96*, 24.
- (149) Eriksen, J.; Foote, C. S. *J. Am. Chem. Soc.* **1980**, *102*, 6083.
- (150) Takamuku, S.; Kuroda, T.; Sakuri, K. *Chem. Lett.* **1982**, 377.
- (151) Yasuka, M.; Pac, C.; Sakurai, H. *J. Chem. Soc., Perkin Trans. 1* **1981**, 746.
- (152) Lewis, F. D.; Simpson, J. T. *J. Am. Chem. Soc.* **1980**, *102*, 7593.
- (153) Balzani, V.; Moggi, L.; Manfrin, M. F.; Bolletta, F. *Coord. Chem. Rev.* **1975**, *15*, 322.
- (154) Creutz, C.; Sutin, N. *Pure Appl. Chem.* **1980**, *52*, 2717.
- (155) Jamieson, M. A.; Serpone, N.; Hoffman, M. Z. *Coord. Chem. Rev.* **1981**, *39*, 121.
- (156) Kalyanasundaram, K. *Coord. Chem. Rev.* **1982**, *43*, 161.
- (157) Gafney, H. D.; Adamson, A. W. *J. Am. Chem. Soc.* **1972**, *94*, 8238.
- (158) Van Houten, J.; Watts, R. *J. Inorg. Chem.* **1978**, *17*, 3381.
- (159) Caspar, J. V.; Meyer, T. J. *J. Am. Chem. Soc.* **1983**, *105*, 5583.
- (160) Bradley, P. G.; Kress, N.; Hornberger, B. A.; Dallinger, R. F.; Woodruff, W. H. *J. Am. Chem. Soc.* **1981**, *103*, 7441.
- (161) Hager, G. D.; Crosby, G. A. *J. Am. Chem. Soc.* **1975**, *97*, 7031.
- (162) Bock, C. R.; Meyer, T. J.; Whitten, D. G. *J. Am. Chem. Soc.* **1975**, *97*, 2909.
- (163) Bock, C. R.; Meyer, T. J.; Whitten, D. G. *J. Am. Chem. Soc.* **1974**, *96*, 4710.
- (164) Amouyal, E.; Zidler, B.; Keller, P.; Moradpour, A. *Chem. Phys. Lett.* **1981**, *20*, 1760.
- (165) De Laive, P. J.; Giannotti, C.; Whitten, D. G. *J. Am. Chem. Soc.* **1978**, *100*, 7413.
- (166) Navon, G.; Sutin, N. *Inorg. Chem.* **1974**, *13*, 2159.
- (167) Juris, A.; Gandolfi, M. F.; Manfrin, M. F.; Balzani, V. *J. Am. Chem. Soc.* **1976**, *98*, 1047.
- (168) Juris, A.; Manfrin, M. F.; Maestri, M.; Serpone, N. *Inorg. Chem.* **1978**, *17*, 2258.
- (169) Toma, H. E.; Creutz, C. *Inorg. Chem.* **1977**, *16*, 545.
- (170) Ballardini, R.; Varani, G.; Scandola, M. A.; Balzani, V. *J. Am. Chem. Soc.* **1976**, *98*, 7432.
- (171) Bolletta, F.; Maestri, M.; Balzani, V. *J. Phys. Chem.* **1976**, *80*, 2499.
- (172) Creutz, C.; Sutin, N. *J. Am. Chem. Soc.* **1976**, *98*, 6384.
- (173) Creutz, C.; Sutin, N. *Inorg. Chem.* **1976**, *15*, 496.
- (174) Lin, C.-T.; Bottcher, W.; Chou, M.; Creutz, C.; Sutin, N. *J. Am. Chem. Soc.* **1976**, *98*, 6536.
- (175) Laurence, G. S.; Balzani, V. *Inorg. Chem.* **1974**, *13*, 2976.
- (176) Kalyanasundaram, K.; Neumann-Spallart, M. *Chem. Phys. Lett.* **1982**, *88*, 7.
- (177) Rosenfeld-Grunwald, T.; Rabani, J. *J. Phys. Chem.* **1980**, *84*, 2981.
- (178) Balzani, V.; Scandola, F.; Orlandi, G.; Sabbatini, N.; Indelli, M. T. *J. Am. Chem. Soc.* **1981**, *103*, 3370.
- (179) Brunschwig, B. S.; Sutin, N. *Chem. Phys. Lett.* **1981**, *77*, 63.
- (180) Brunschwig, B. S.; Sutin, N. *Inorg. Chem.* **1979**, *18*, 1731.
- (181) Giro, G.; Casalbore, G.; DiMarco, P. G. *Chem. Phys. Lett.* **1980**, *71*, 476.
- (182) Anderson, C. P.; Salmon, D. J.; Meyer, T. J.; Young, R. C. *J. Am. Chem. Soc.* **1977**, *99*, 1981.
- (183) Maestri, M.; Gratzel, M. *Ber. Bunsenges. Phys. Chem.* **1977**, *81*, 504.
- (184) Shioyama, H.; Masuhara, H.; Mataga, N. *Chem. Phys. Lett.* **1982**, *88*, 161.
- (185) Kitamura, N.; Okano, S.; Tazuke, S. *Chem. Phys. Lett.* **1982**, *90*, 13.
- (186) Creutz, C. *Inorg. Chem.* **1978**, *17*, 1046.
- (187) Wrighton, M.; Markham, J. *J. Phys. Chem.* **1973**, *77*, 3042.
- (188) Takagi, K.; Ogata, Y. *J. Org. Chem.* **1982**, *47*, 3042.
- (189) Gutierrez, A. R.; Meyer, T. J.; Whitten, D. G. *Mol. Photochem.* **1976**, *7*, 349.
- (190) Ballardini, R.; Varani, G.; Indelli, T.; Scandola, F.; Balzani, V. *J. Am. Chem. Soc.* **1978**, *100*, 7219.
- (191) Ohno, T.; Kato, S. *Bull. Chem. Soc. Jpn.* **1984**, *57*, 1528.
- (192) Rice, S. F.; Gray, H. B. *J. Am. Chem. Soc.* **1981**, *103*, 1593.
- (193) Rice, S. F.; Milder, S. J.; Gray, H. B.; Goldbeck, R. A.; Kliger, D. S. *Coord. Chem. Rev.* **1982**, *43*, 349.
- (194) Milder, S. J.; Goldbeck, R. A.; Kliger, D. S.; Gray, H. B. *J. Am. Chem. Soc.* **1980**, *102*, 6761.
- (195) Troglor, W. C.; Solomon, E. I.; Gray, H. B. *Inorg. Chem.* **1977**, *16*, 3031.
- (196) Miskowski, V. M.; Goldbeck, R. A.; Kliger, D. S. *Inorg. Chem.* **1979**, *18*, 86.

- (197) Nocera, D. G.; Gray, H. B. *J. Am. Chem. Soc.* **1981**, *103*, 7349.
- (198) Che, C.-M.; Butler, L. G.; Gray, H. B. *J. Am. Chem. Soc.* **1981**, *103*, 7796.
- (199) Che, C.-M.; Butler, L. G.; Gray, H. B.; Crooks, R. M.; Woodruff, W. H. *J. Am. Chem. Soc.* **1983**, *105*, 5492.
- (200) Heuer, W. B.; Totten, M. D.; Rodman, G. S.; Hebert, E. J.; Tracy, H. J.; Nagle, J. K. *J. Am. Chem. Soc.* **1984**, *106*, 1163.
- (201) Burrows, H. D.; Kemp, T. *J. Chem. Soc. Rev.* **1974**, *3*, 139.
- (202) Marcantonatos, M. D. *J. Chem. Soc., Faraday Trans. 1* **1979**, 2252.
- (203) Matsushima, R.; Fujimori, H.; Sakuraba, S. *J. Chem. Soc., Faraday Trans. 1* **1974**, *70*, 1702.
- (204) Burrows, H. D.; Formosinho, S. J.; da Graca Miguel, M.; Coelho, F. P. *J. Chem. Soc., Faraday Trans. 1* **1976**, *72*, 163.
- (205) Burrows, H. D.; Formosinho, S. J. *J. Phys. Chem.* **1982**, *86*, 1042.
- (206) Rosenfeld-Grunwald, T.; Brandeis, M.; Rabani, J. *J. Phys. Chem.* **1982**, *86*, 4745.
- (207) Matsushima, R. *Chem. Lett.* **1973**, 115.
- (208) Rehorek, D.; Rehorek, A.; Ackermann, M.; Thomas, P.; Henning, H.; Santereau, H. *J. Signal AM* **9** **1981**, *4*, 291.
- (209) Sergeeva, G.; Chibisov, A.; Levshin, L.; Karyakin, A. *J. Chem. Soc., Chem. Commun.* **1974**, 159.
- (210) Greatorex, D.; Hill, R. J.; Kemp, T. J.; Stone, T. J. *J. Chem. Soc., Faraday Trans. 1* **1972**, *68*, 2059.
- (211) Hill, R. J.; Kemp, T. J.; Allen, D. M.; Cox, A. *J. Chem. Soc., Faraday Trans. 1* **1974**, *70*, 847.
- (212) Greatorex, D.; Richard, J. H.; Kemp, T. J.; Stone, T. T. *J. Chem. Soc., Faraday Trans. 1* **1974**, *70*, 216.
- (213) Matsushima, R. *J. Am. Chem. Soc.* **1972**, *94*, 6010.
- (214) Darwent, J. R.; Douglas, P.; Harriman, A.; Porter, G.; Richoux, M. C. *Coord. Chem. Rev.* **1982**, *44*, 83.
- (215) Whitten, D. G.; Lopp, I. G.; Wildes, P. D. *J. Am. Chem. Soc.* **1968**, *90*, 7186.
- (216) Lopp, I. G.; Hendren, R. W.; Wildes, P. D.; Whitten, D. G. *J. Am. Chem. Soc.* **1970**, *92*, 6440.
- (217) Harriman, A.; Porter, G.; Wilowska, A. *J. Chem. Soc., Faraday Trans. 2* **1984**, *80*, 191.
- (218) Roy, J. K.; Whitten, D. G. *J. Am. Chem. Soc.* **1971**, *93*, 7093.
- (219) Roy, J. K.; Whitten, D. G. *J. Am. Chem. Soc.* **1972**, *94*, 7163.
- (220) Roy, J. K.; Carroll, F. A.; Whitten, D. G. *J. Am. Chem. Soc.* **1974**, *96*, 6349.
- (221) Whitten, D. G.; Roy, J. K.; Carroll, F. A. In "The Exciplex"; Gordon, M.; Ware, W. R., Eds.; Academic: New York, 1975; pp 247-274.
- (222) Gouterman, M.; Holten, D. *Photochem. Photobiol.* **1977**, *25*, 85.
- (223) Livingston, R.; Ke, C. *J. Am. Chem. Soc.* **1950**, *72*, 909.
- (224) Livingston, R.; Thompson, L.; Ramaro, M. V. *J. Am. Chem. Soc.* **1950**, *72*, 1073.
- (225) Gouterman, M.; Stevenson, P. E. *J. Chem. Phys.* **1962**, *37*, 2266.
- (226) Yamada, S.; Sato, T.; Kano, K.; Ogawa, T. *Photochem. Photobiol.* **1983**, *37*, 257.
- (227) Holten, D.; Gouterman, M.; Paeson, W. W.; Windson, M. W.; Rockley, M. E. *Photochem. Photobiol.* **1976**, *73*, 415.
- (228) Harriman, A.; Porter, G.; Richoux, M. C. *J. Chem. Soc., Faraday Trans. 2* **1981**, *77*, 1175.
- (229) Harriman, A.; Porter, G.; Richoux, M. C. *J. Chem. Soc., Faraday Trans. 2* **1981**, *77*, 883.
- (230) Harriman, A.; Richoux, M. C. *J. Chem. Soc., Faraday Trans. 2* **1982**, *78*, 1973.
- (231) Gore, B. L.; Harriman, A.; Richoux, M. C. *J. Photochem.* **1982**, *19*, 209.
- (232) Whitten, D. G. *Rev. Chem. Intermed.* **1978**, *2*, 107.
- (233) Seely, G. R. *Photochem. Photobiol.* **1978**, *27*, 639.
- (234) Harriman, A.; Porter, G.; Searle, N. *J. Chem. Soc., Faraday Trans. 2* **1979**, *75*, 1515.
- (235) Harriman, A.; Porter, G. *J. Chem. Soc., Faraday Trans. 2* **1980**, *76*, 1421.
- (236) Harriman, A.; Porter, G. *J. Chem. Soc., Faraday Trans. 2* **1980**, *76*, 1429.
- (237) Cox, G. S.; Whitten, D. G.; Giannotti, C. *Chem. Phys. Lett.* **1979**, *67*, 511.
- (238) Gamache, R. E.; McMillin, D. R.; Marnot, P. A.; Sauvage, J.-P. *J. Am. Chem. Soc.* **1985**, *107*, 1141.
- (239) Cohen, S. G.; Parola, A.; Parsons, G. H. *Chem. Rev.* **1973**, *73*, 141.
- (240) Wagner, P. J. *Top. Curr. Chem.* **1976**, *66*, 1.
- (241) Turro, N. J.; Engel, R. *J. Am. Chem. Soc.* **1969**, *91*, 7113.
- (242) Knibbe, H.; Rehm, D.; Weller, A. *Ber. Bunsenges. Phys. Chem.* **1968**, *72*, 257.
- (243) Rehm, D.; Weller, A. *Ber. Bunsenges. Phys. Chem.* **1969**, *73*, 834.
- (244) Guttenplan, J. B.; Cohen, S. G. *J. Am. Chem. Soc.* **1972**, *94*, 1972.
- (245) Brown, R. G.; Henderson, S.; May, B.; Shankey, J. *J. Photochem.* **1984**, *26*, 33.
- (246) Vittimberga, B. University of Rhode Island, personal communication, 1985.
- (247) Koizumi, M.; Yamashita, H. *Z. Phys. Chem. (Munich)* **1968**, *57*, 103.
- (248) Yamashita, H.; Kokubun, H.; Koizumi, H. *Bull. Chem. Soc. Jpn.* **1968**, *41*, 2312.
- (249) Bartholomew, R. F.; Davidson, R. S.; Lambeth, P. F. *J. Chem. Soc., Perkin Trans. 2* **1972**, 577.
- (250) Arimitsu, S.; Masuhara, H.; Mataga, N.; Tsubomura, H. *J. Phys. Chem.* **1975**, *79*, 1255.
- (251) Hirata, Y.; Kanda, Y.; Mataga, N. *J. Phys. Chem.* **1983**, *87*, 1659.
- (252) Peters, K. S.; Freilich, S. C.; Schaefer, C. G. *J. Am. Chem. Soc.* **1980**, *102*, 5701.
- (253) Schaefer, C. G.; Peters, K. S. *J. Am. Chem. Soc.* **1980**, *102*, 7566.
- (254) Simon, J. D.; Peters, K. S. *J. Am. Chem. Soc.* **1981**, *103*, 6403.
- (255) Simon, J. D.; Peters, K. S. *J. Am. Chem. Soc.* **1982**, *104*, 6542.
- (256) Peters, K. S.; Pange, E.; Rudzki, J. *J. Am. Chem. Soc.* **1982**, *104*, 5535.
- (257) Manning, L. E.; Peters, K. S. *J. Am. Chem. Soc.* **1983**, *105*, 5708.
- (258) Simon, J. D.; Peters, K. S. *Acc. Chem. Res.* **1984**, *17*, 277.
- (259) Hub, W.; Schneider, S.; Dorr, F.; Simpson, J. T.; Oxman, J. D.; Lewis, F. D. *J. Am. Chem. Soc.* **1982**, *104*, 2049.
- (260) Hub, W.; Schneider, S.; Dorr, F.; Oxman, J. D.; Lewis, F. D. *J. Am. Chem. Soc.* **1984**, *106*, 701.
- (261) Hub, W.; Schneider, S.; Dorr, F.; Oxman, J. D.; Lewis, F. D. *J. Am. Chem. Soc.* **1984**, *106*, 708.
- (262) Roth, H. D.; Lamola, A. A. *J. Am. Chem. Soc.* **1974**, *96*, 6270.
- (263) Hendricks, B. M. P.; Walter, R. I.; Fischer, H. *J. Am. Chem. Soc.* **1979**, *101*, 2378.
- (264) Roth, H. D.; Manion, M. L. *J. Am. Chem. Soc.* **1975**, *97*, 6886.
- (265) Reference 1, Chapter 7.
- (266) Taniguchi, Y.; Nishina, Y.; Mataga, N. *Bull. Chem. Soc. Jpn.* **1972**, *45*.
- (267) Taniguchi, Y.; Mataga, N. *Chem. Phys. Lett.* **1972**, *13*, 596.
- (268) Masuhara, H.; Hino, T.; Mataga, N. *J. Phys. Chem.* **1975**, *79*, 994.
- (269) Beecroft, R. A.; Davidson, R. S.; Whelan, T. D. *J. Chem. Soc., Chem. Commun.* **1978**, 911.
- (270) De Schryver, F. C.; Beans, N. *Adv. Photochem.* **1977**, *10*, 359.
- (271) Ide, R.; Sakata, Y.; Misumi, S.; Okada, T.; Mataga, N. *J. Chem. Soc., Chem. Commun.* **1972**, 1009.
- (272) Grabowski, Z. R.; Dobkowski, J. *Pure Appl. Chem.* **1983**, *55*, 245.
- (273) Winnik, M. A. *Chem. Rev.* **1981**, *81*, 491.
- (274) Pragst, F.; Hamann, H. J.; Teuchner, K.; Dachne, S. *J. Lumin.* **1978**, *17*, 425.
- (275) Davidson, R. S.; Tretheway, K. R. *J. Chem. Soc., Chem. Commun.* **1976**, 827.
- (276) Luo, X. J.; Beddard, G. S.; Porter, G.; Davidson, R. S.; Whelan, T. D. *J. Chem. Soc., Faraday Trans. 1* **1982**, *78*, 3467.
- (277) Vanderauwera, P.; De Schryver, F. C.; Weller, A.; Winnik, M. A.; Zachariasse, K. A. *J. Phys. Chem.* **1984**, *88*, 2964.
- (278) Crawford, M. K.; Wang, Y.; Eisenthal, K. B. *Chem. Phys. Lett.* **1981**, *79*, 529.
- (279) Wang, Y.; Crawford, M. C.; Eisenthal, K. B. *J. Am. Chem. Soc.* **1982**, *104*, 5874.
- (280) Mataga, N.; Mitiga, M.; Nishimura, T. *J. Mol. Struct.* **1978**, *47*, 199.
- (281) Okada, T.; Mitiga, M.; Mataga, N.; Sukata, Y.; Misumi, S. *J. Am. Chem. Soc.* **1981**, *104*, 4715.
- (282) Okada, T.; Karaki, I.; Matsuzawa, E.; Mataga, N.; Sakata, Y.; Oisuni, S. *J. Phys. Chem.* **1981**, *85*, 3957.
- (283) Harriman, A.; Porter, G.; Wilowska, A. *J. Chem. Soc., Faraday Trans. 2* **1984**, *80*, 191.
- (284) Tabushi, N.; Koga, N.; Yanagita, M. *Tetrahedron Lett.* **1979**, 257.
- (285) Ho, T. H.; Mc Intosh, A. R.; Bolton, J. R. *Nature (London)* **1980**, *286*, 254.
- (286) Mc Intosh, A. R.; Siemiarzyc, A.; Bolton, J. R.; Stillman, M. J.; Ho, T. F.; Weedon, A. C. *J. Am. Chem. Soc.* **1983**, *105*, 7215.
- (287) Siemiarzyc, A.; Mc Intosh, A. R.; Ho, T. F.; Stillman, M. J.; Roach, K. J.; Weedon, A. C.; Bolton, J. R.; Connolly, J. S. *J. Am. Chem. Soc.* **1983**, *105*, 7224.
- (288) Dalton, J.; Milgrom, L. R. *J. Chem. Soc., Chem. Commun.* **1979**, 609.
- (289) Kong, J. L. Y.; Spears, K. G.; Loach, P. A. *Photochem. Photobiol.* **1982**, *35*, 545.
- (290) Mataga, N.; Karen, A.; Okada, T.; Nishitani, S.; Kurata, N.; Sakata, Y.; Misumi, S. *J. Phys. Chem.* **1984**, *88*, 5138.
- (291) Lindsey, J. S.; Mauzerall, D. C.; Kinschitz, H. *J. Am. Chem. Soc.* **1983**, *105*, 6528.
- (292) Wasielewski, M. R.; Niemczyk, M. P. *J. Am. Chem. Soc.* **1984**, *106*, 5043.
- (293) Joran, A. D.; Leland, B. A.; Geller, G. G.; Hopfield, J. J.; Dervan, P. B. *J. Am. Chem. Soc.* **1984**, *106*, 6090.
- (294) Pasman, P.; Koper, N. W.; Verhoeven, J. W. *Recl. Trav. Chim. Pays-Bas* **1982**, *101*, 363.

- (295) Calcaterra, L. T.; Closs, G. L.; Miller, J. R. *J. Am. Chem. Soc.* **1983**, *105*, 670.
- (296) Kosower, E. M. *J. Am. Chem. Soc.* **1985**, *107*, 1114.
- (297) Keller, R. A.; Dolby, L. J. *J. Am. Chem. Soc.* **1967**, *89*, 2768.
- (298) Keller, R. A.; Dolby, L. J. *J. Am. Chem. Soc.* **1969**, *91*, 1293.
- (299) Pasman, P.; Rib, F.; Verhoeven, J. W. *J. Am. Chem. Soc.* **1982**, *104*, 5127.
- (300) Shizuka, H.; Nakamura, M.; Morita, T. *J. Phys. Chem.* **1979**, *83*, 2019.
- (301) Hoffman, R. *Acc. Chem. Res.* **1971**, *4*, 1.
- (302) Winnik, M. A.; Hsiao, C. K. *Chem. Phys. Lett.* **1975**, *33*, 518.
- (303) Mar, A.; Fraser, S.; Winnick, M. A. *J. Am. Chem. Soc.* **1981**, *103*, 4941.
- (304) Wagner, P. J.; Siebert, E. J. *J. Am. Chem. Soc.* **1981**, *103*, 7335.
- (305) Wismontski-Knittel, T.; Kilp, T. *J. Phys. Chem.* **1984**, *88*, 110.
- (306) Maskukara, H.; Maeda, Y.; Mataga, N.; Tomita, K.; Tatemitsu, H.; Sukata, Y.; Misumi, S. *Chem. Phys. Lett.* **1980**, *69*, 182.
- (307) Masuhara, H.; Maeda, Y.; Nakajo, H.; Mataga, N.; Tomita, K.; Tatemitsu, H.; Sakata, Y.; Misumi, S. *J. Am. Chem. Soc.* **1981**, *103*, 634.
- (308) Meyers, T. J. *Acc. Chem. Res.* **1977**, *10*, 94.
- (309) Meyers, T. J. In "Mechanistic Aspects of Inorganic Reactions", ACS Symposium Series 198; Rorabacker, D. B., Endicott, J. F., Eds.; American Chemical Society: Washington, DC, 1982; Chapter 6.
- (310) Tom, G. M.; Creutz, C.; Taube, H. *J. Am. Chem. Soc.* **1974**, *96*, 7827.
- (311) Curtis, J. C.; Meyer, T. J. *J. Am. Chem. Soc.* **1978**, *100*, 6284.
- (312) Norton, K. A.; Hurst, J. K. *J. Am. Chem. Soc.* **1982**, *104*, 5960.
- (313) Beecroft, R. A.; Davidson, R. S.; Whelan, T. D. *J. Chem. Soc., Chem. Commun.* **1982**, *911*.
- (314) Larson, J. R.; Petrich, J. W.; Yang, N. C. *J. Am. Chem. Soc.* **1982**, *104*, 5000.
- (315) Mes, G. F.; van Ramesdonk, H. J.; Verhoeven, J. W. *Recl. Trav. Chim. Pays-Bas* **1983**, *102*, 55.
- (316) Mes, G. F.; van Ramesdonk, H. J.; Verhoeven, J. W. *J. Am. Chem. Soc.* **1984**, *106*, 1335.
- (317) Moore, T. A.; Gust, D.; Mathis, P.; Mialocq, J. C.; Chachaty, C.; Bensasson, R. V.; Land, E. J.; Doizi, D.; Liddell, P. A.; Lehman, G. A.; Nemeth, G. A.; Moore, A. L. *Nature (London)* **1984**, *307*, 630.
- (318) Ledwith, A. *Acc. Chem. Res.* **1972**, *5*, 133.
- (319) Hixson, S. S. In "Organic Photochemistry"; Padwa, A., Ed.; Marcel Dekker: New York, 1979; Vol. 4, p 191.
- (320) Arnold, D. R.; Wong, P. C.; Maroulis, A. J.; Cameron, T. S. *Pure Appl. Chem.* **1980**, *52*, 2609.
- (321) Mattes, S. L.; Farid, S. *Acc. Chem. Res.* **1982**, *15*, 80.
- (322) Farid, S.; Shealer, S. E. *J. Chem. Soc., Chem. Commun.* **1973**, 677.
- (323) Farid, S.; Hartman, S. E.; Evans, T. R. In "The Exciplex"; Gordon, M., Ware, W. R., Eds.; Academic: New York, 1975; p 327.
- (324) Mizuno, K.; Kaji, R.; Otsuji, Y. *Chem. Lett.* **1977**, 1027.
- (325) Mizuno, K.; Kaji, R.; Okada, H.; Otsuji, Y. *J. Chem. Soc., Chem. Commun.* **1978**, 594.
- (326) Neunteufel, R. A.; Arnold, D. R. *J. Am. Chem. Soc.* **1973**, *95*, 4080.
- (327) Shigemitsu, Y.; Arnold, D. R. *J. Chem. Soc., Chem. Commun.* **1975**, 407.
- (328) Mattes, S. L.; Farid, S. *J. Am. Chem. Soc.* **1983**, *105*, 1386.
- (329) Mattes, S. L.; Farid, S. *J. Chem. Soc., Chem. Commun.* **1980**, 126.
- (330) Turro, N. J.; Tung, C. H.; Gould, I. A.; Griffin, G. W.; Smith, R. L.; Manmade, A. *J. Photochem.* **1984**, *24*, 263.
- (331) Tung, C. H. Ph.D. Dissertation, Columbia University 1984.
- (332) Das, P. K.; Muller, A. J.; Griffin, G. W.; Gould, I. R.; Tung, C. H.; Turro, N. J. *Photochem. Photobiol.* **1984**, *39*, 281.
- (333) Reichel, L. W.; Griffin, G. W.; Muller, A. J.; Das, P. K.; Ege, S. N. *Can. J. Chem.* **1984**, *62*, 424.
- (334) Barber, R. A.; deMayo, P.; Okada, K.; Wong, S. K. *J. Am. Chem. Soc.* **1982**, *104*, 4995.
- (335) Roth, H. D.; Schilling, M. L. M.; Jones, G., II. *J. Am. Chem. Soc.* **1981**, *103*, 1246.
- (336) Roth, H. D.; Schilling, M. L. M. *J. Am. Chem. Soc.* **1981**, *103*, 7210.
- (337) Jones, G., II; Chiang, S. H.; Becker, W. G.; Welch, J. A. *J. Phys. Chem.* **1982**, *86*, 2805.
- (338) Jones, G., II; Becker, W. G. *Chem. Phys. Lett.* **1982**, *85*, 271.
- (339) Turro, N. J.; Cherry, W. R.; Mirbach, M. F.; Mirbach, M. J. *J. Am. Chem. Soc.* **1977**, *99*, 7388.
- (340) Jones, G., II; Xuan, P. T.; Schwarz, W. *Tetrahedron Lett.* **1982**, *23*, 5505.
- (341) Jones, G., II; Schwarz, W.; Malba, V. *J. Phys. Chem.* **1982**, *86*, 2286.
- (342) Schwarz, W.; Dangel, K. M.; Jones, G., II; Bargon, J. *J. Am. Chem. Soc.* **1982**, *104*, 5686.
- (343) Evans, T. R.; Wake, R. W.; Sifrain, M. M. *Tetrahedron Lett.* **1973**, 701.
- (344) Jones, G., II; Becker, W. G. *J. Am. Chem. Soc.* **1981**, *103*, 4630.
- (345) Erickson, J.; Foote, C. S.; Parker, T. L. *J. Am. Chem. Soc.* **1977**, *99*, 6455.
- (346) Spada, L. T.; Foote, C. S. *J. Am. Chem. Soc.* **1980**, *102*, 391.
- (347) Mattes, S. L.; Farid, S. *J. Chem. Soc., Chem. Commun.* **1980**, 457.
- (348) Manring, L. E.; Ericksen, J.; Foote, C. S. *J. Am. Chem. Soc.* **1980**, *102*, 4275.
- (349) Mattes, S. L.; Farid, S. *J. Am. Chem. Soc.* **1982**, *104*, 1454.
- (350) Steichen, D. S.; Foote, F. S. *J. Am. Chem. Soc.* **1981**, *102*, 1855.
- (351) Schaap, A. P.; Lopez, L.; Anderson, S. D.; Gagnon, S. G. *Tetrahedron Lett.* **1982**, *23*, 5493.
- (352) Schaap, A. P.; Lopez, L.; Gagnon, S. D. *J. Am. Chem. Soc.* **1983**, *105*, 663.
- (353) Schaap, A. P.; Siddiqui, S.; Prasad, G.; Palomino, E.; Lopez, L. *J. Photochem.* **1984**, *25*, 167.
- (354) Manring, L. E.; Kramer, M. K.; Foote, C. S. *Tetrahedron Lett.* **1984**, *25*, 2533.
- (355) Saito, I.; Matsuura, T.; Inoue, K. *J. Am. Chem. Soc.* **1981**, *103*, 188.
- (356) Nelsen, S. F.; Cunkle, G. T.; Evans, D. H.; Haller, K. J.; Kaftory, M.; Kirste, B.; Kurrak, H.; Clark, T. *J. Am. Chem. Soc.* **1985**, *107*, 3829.
- (357) Laufer, G. E. A.; Dreeskamp, H.; Zachariasse, K. A. *Chem. Phys. Lett.* **1985**, *121*, 523.
- (358) Miyagawa, K.; Murai, H.; I'Haya, Y. T. *Chem. Phys. Lett.* **1985**, *118*, 140.
- (359) Li, T. T.-T.; Weaver, M. J. *J. Am. Chem. Soc.* **1984**, *106*, 6107.
- (360) "Organic Phototransformations in Nonhomogeneous Media"; ACS Symposium Series 278; Fox, M. A., Ed.; American Chemical Society: Washington, DC, 1985.
- (361) Gonzalez, M. C.; McIntosh, A. R.; Bolton, J. R.; Weedon, A. C. *J. Chem. Soc., Chem. Commun.* **1984**, 1138.
- (362) Buhks, E.; Wilkins, R. G.; Isied, S. S.; Endicott, J. F. In "Mechanistic Aspects of Inorganic Reactions"; ACS Symposium Series 198; Rorabacker, D. B., Endicott, J. F., Eds.; American Chemical Society: Washington, DC, 1982; Chapter 9.
- (363) Darwent, J. R.; McCubbin, I.; Porter, G. J. *J. Chem. Soc., Faraday Trans. 2* **1982**, *78*, 903.
- (364) Cano-Yelo, H.; Deronzier, A. *J. Chem. Soc., Perkin Trans. 2* **1984**, 1093.
- (365) A Paterno-Buchi-like intermediate has been proposed in the rearrangements of methoxybenzoin esters (Sheehan, J. C.; Wilson, R. M.; Oxford, A. W. *J. Am. Chem. Soc.* **1971**, *93*, 7222). We thank one referee for kindly bringing this work to our attention.